

GENERATING SET GE 455 FSX

The images are for reference



FEATURES

- Available version with STAGE 3A engine
- Bundled base suitable to contain any liquids leakage from engine avoiding environmental pollution
- Oil drain pump
- Fuel pre-filter with water separator
- Large doors for better and easy maintenance (air, oil, fuel filters replacement)
- 2 central lifting eyes
- Control panel with digital control unit available with automatic or manual version
- Suitable for a wide range of uses in general construction
- Supersilenced
- Meets EC directives for noise and safety



POWER RATINGS

* Stand-By three-phase power (LTP)	450 kVA (360 kW) 400 V / 649.5 A	440 kVA (352 kW) 400 V / 635.1 A
* PRP three-phase power	410 kVA (328 kW) 400 V / 591.8 A	400 kVA (320 kW) 400 V / 577.4 A
* PRP single-phase power	315 kVA (252 kW) / 400V / 455.2 A	
Frequency	50 Hz	
Cos φ	0.8	

* Output powers according to ISO 8528-1

DEFINITION

Valid declared powers up to the followings environmental conditions: temperature 25°C, altitude 100 meters above sea level)

LTP power: stand-by power: Maximum available power for use with variable loads for a yearly number of hours limited at 500 h. No overload is admitted.

PRP power: continue power with variable loads. Maximum power for use with variable loads for a yearly illimited nubers of hours.

COP power: continuous power with constant load. Maximum power for use with constant loads for a yearly unlimited numbers of hours.

ENGINE 1500 RPM

4 STROKE, DIRECT INJECTION, TURBOCHARGED

Model	FPT (IVECO) C13 TE3A	FPT (IVECO) C13 TE2F (Stage 3A)
* Stand-By net power	387 kW (526 hp)	377 kW (513 hp)
* PRP net power	352 kW (478.7 hp)	342 kW (465 hp)
* COP net power	/	269 kW (366 hp)
Cylinders / Displacement	6/ 12880 cm ³ (12.88 lit.)	
Bore / Stroke	135 / 150 (mm)	
Compression ratio	16.5 : 1	
BMEP (Brake Mean Effective Pressure : LTP - PRP)	2484.5 kPa - 2258.6 kPa	2485 kPa - 2259 kPa
Speed governor type	Electronic	
FUEL CONSUMPTION		
110 % (Stand-by power)	208.1 g/kWh - 98.5 lit./h	204.5 g/kWh - 97.4 lit./h
100 % to PRP	208 g/kWh - 87.5 lit./h	213 g/kWh - 92.9 lit./h
75 % to PRP	203.6 g/kWh - 72.5 lit./h	234.5 g/kWh - 81 lit./h
50 % to PRP	205 g/kWh - 48.6 lit./h	243.2 g/kWh - 53 lit./h
COOLING SYSTEM		
Total system cap. - only engine	47.5 lit. - 19.5 lit	67 lit. - 19.5 lit.
Fan air flow	408 m ³ /min.	546 m ³ /min.
LUBRIFICATION SYSTEM		
Total oil system capacity	35 lit.	
Oil capacity in sump	14 lit. (min) - 27 lit. (max)	
Oil consumption at full load	< 0.17 lit./h	< 0.18 lit./h

* Output powers according to ISO 3046-1

EXHAUST SYSTEM		
Maximum exhaust gas flow	36.8 kg/mim.	31.12 kg/mim.
Max. exhaust gas temp.	445 °C	520 °C
Maximum back pressure	5 kPa (0,05 bar)	
External diameter exhaust pipe	/	
ELECTRICAL SYSTEM		
Starter motor power	5.5 kW	
Battery charging alternator cap.	90 A	
Cold start	- 10 °C	
With cold start aid	- 25 °C	
AIR FILTER		
Combustion air flow	29.5 m ³ /min.	
HEAT REJECTED AT FULL LOAD		
To exhaust system	703 kcal/kWh	591 kcal/kWh
To water and oil	370 kcal/kWh	321 kcal/kWh
Radiated to room	32 kcal/kWh	100 kcal/kWh
To charge cooler	179 kcal/kWh	213 kcal/kWh



ALTERNATOR

SYNCHRONOUS, THREE-PHASE, SELF-EXCITED, SELF-REGULATED, BRUSHLESS	
Continuous power	410 kVA
Stand-by power	450 kVA
Three phase voltage	380-415 Vac
Frequency	50 Hz
Cos φ	0.8
Model A.V.R.	Digitale MEC-20
Voltage regulation acc.	± 0,5 %
Sustained short circuit current	3 In A
Transient dip (100% load)	< 20 %
Recovery time	< 0,3 sec
Efficiency at 100% load	93.7 % (400V - Cos φ 0,8)
Insulation	Class H
Connection - Terminals	Star - N°12
Electromagnetic compatibility (R.F.I. suppr.)	EN 55011
Waveform distortion - THD	< 2 %
Telephone interference - THF	< 2 %

REACTANCES (410 kVA - 400V)	
Direct axis synchronous - Xd	330 %
Direct axis transient - X'd	29.5 %
Subdirect axis transient - X''d	13.2 %
Quadrature axis synchronous - Xq	175 %
Quadr. axis subtransient - X''q	15.6 %
Negative sequence - X2	14.4 %
Zero sequence - X0	3.3 %
TIME CONSTANTS	
Transient - T'd	0.14 sec
Subtransient - T''d	0.014 sec
Open circuit - T'do	1.6 sec
Armature - Ta	0.018 sec
Short-circuit ratio Kcc	0.38
Grado di Protezione IP	IP 23
Cooling air flow	0.83 m³/sec.
Coupling Bearing	Direct SAE 1 -14 - N°1

GENERAL SPECIFICATIONS

Fuel tank capacity	580 lt.	
Running time (75% to PRP)	8.5 h	7.5 h
Starter battery	24 Vdc (2x12 Vdc -180Ah)	
IP protection degree	IP 44	

* Measured acoustic power LwA (pressure LpA)	97 dB(A) (72 dB(A) @ 7m)
* Guaranteed acoustic power LwA (pressure LpA)	98 dB(A) (73 dB(A) @ 7m)
Performance class (ISO 8528)	G3

* Acoustic power according to European Directive 2000/14/CE

CONTROL PANEL

- Controller AMF 25
- Controller supply switch
- Siren
- Emergency stop button
- TCM 35 remote control plug
- Four pole circuit breaker
- PAC (ATS) plug - Automatic control panel only
- Battery charger - Automatic control panel only
- Earth terminal (PE)

EP6 CONTROLLER CHARACTERISTICS	
Operating mode	<ul style="list-style-type: none"> • OFF - MAN. - AUTO - TEST
Display	<ul style="list-style-type: none"> • Graphic back-light LCD display 128x64 pixels
LEDs	<ul style="list-style-type: none"> • Gen-set voltage OK • Gen-set failure • GCB ON (only for Automatic transfer unit) • Mains voltage OK (only for Automatic transfer unit) • Mains failure (only for Automatic transfer unit) • MCB ON (only for Automatic transfer unit)
Buttons	<ul style="list-style-type: none"> • START button • STOP button • FAULT RESET button • RESET HORN button • MODE selection button • Pulsante chiusura/apertura GCB button • Pulsante chiusura/apertura MCB button • N° 4 buttons for controller programming
Generator Measures	<ul style="list-style-type: none"> • Voltage : L1-L2 / L2-L3 / L3-L1 - N-L1/N-L2/N-L3 • Current : I1 - I2 - I3 • Powers : kVA - kW - kVAR (totali e per fase) • Energy : kVAh - kWh - kVARh • Cos φ (medium and per phase) • Frequency
Engine Measures	<ul style="list-style-type: none"> • Water temperature • Oil pressure • Fuel level • Rpm meter • Battery voltage • Maintenance • Hours meter • Starts number
Generator Protections	<ul style="list-style-type: none"> • Overload • Overcurrent • Short circuit • Over-Undervoltage • Over-Underfrequency • Voltage asymmetry • Unbalanced current • Phase sequence
Engine Protections	<ul style="list-style-type: none"> • Overspeed • High water temperature warning • Low oil pressure warning • Low fuel level warning • Over-Under battery voltage • Battery charge alternator failure • Start failure • Stop failure • Emergency stop • Low water level shutdown (option)

AMF functions (Automatic control panel only)	<ul style="list-style-type: none"> • Measure mains voltage : L1-L2 / L2-L3 / L3-L1 - N-L1/N-L2/N-L3 • Measure mains frequency • Three phase detection • Over-Under mains voltage • Over-Under mains frequency • Voltage asymmetry • Phase sequence • Dual mutual stand-by application
Features	<ul style="list-style-type: none"> • Event log and alarms • 2 tests run scheduler (Automatic test or scheduled starts) • Engine idle management (Idle) • Remote Start and Stop • Pre-heating • 2 selectable languages (other languages available) • Setpoints adjustable via controller buttons or PC • Direct connection to engines with ECU via Can bus J1939 • Configurable inputs and outputs (only via PC) • IP65 protection • Operation temperature: -20°C / +70°C
Communication	<ul style="list-style-type: none"> • RTU Modbus (optional board with RS232 & RS485 outputs is needed) • TCP/IP Modbus (optional Ethernet board with RJ45 output is needed) • SNMP Modbus (optional Ethernet board with RJ45 output is needed) • Internet (optional Ethernet board optional is needed) • GSM/GPRS (integrated Modem board optional is needed) for Gen-set remote control via SMS or internet

CONTROL PANEL VERSION WITH OUTPUT SOCKETS	
SOCKETS Each socket is protect by own automatic switch. Circuit breaker for 125A and 63A sockets. GFI and circuit breaker 30mA for 32A and 16A socket.	1x 400V 125A 3P+T CEE 1x 400V 63A 3P+T CEE 1x 400V 32A 3P+T CEE 1x 400V 16A 3P+T CEE 1x 230V 16A 2P+T CEE 1x 230V 16A 2P+T SCHUKO



WEIGHT - DIMENSIONS AND ACCESSORIES

GE 455 FSX



DRY WEIGHT MACHINE:

- 4240 kg

Generating set pictured may include optional accessories.



DIMENSIONS DRAW

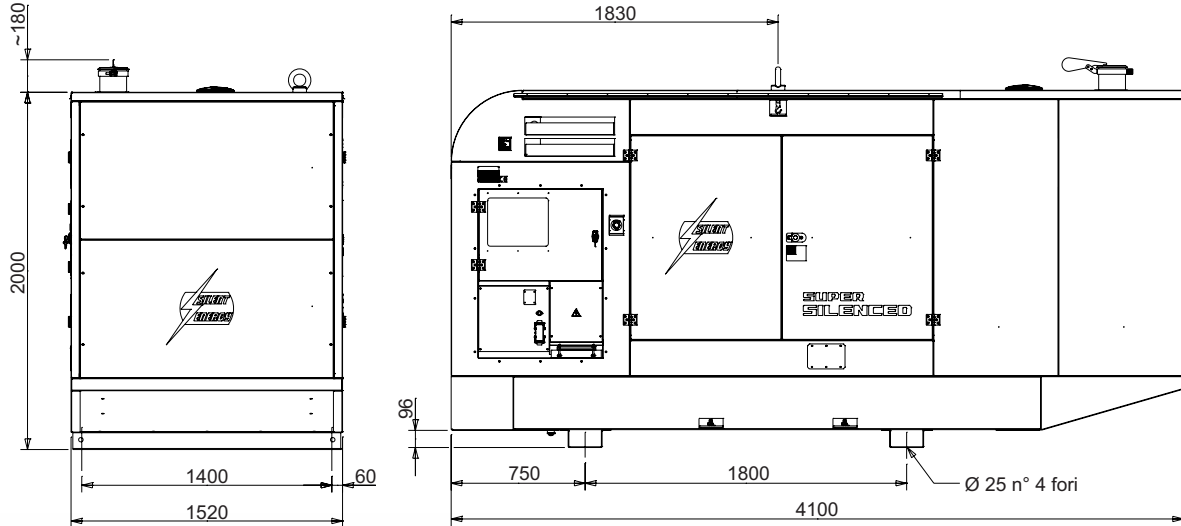

OPTIONS ON REQUEST

- Automatic transfer switch unit (ATS) PAC 550-M (800A)
- Remote control TCM35
- Earthing kit
- Container feet kit

VERSIONS ON REQUEST

- Version with manual control panel 6 output sockets EC and SCHUKO (see Control board with output sockets section)
- Manual digital control panel (without sockets)
- Parallel switch board

FACTORY INSTALLATION OPTIONS

- Engine water heater WH
- Low level water sensor
- 3-way valve fuel system with quick connection for external fuel tank supply
- Main battery switch
- Automatic fuel transfer pump
- PMG - permanent magnet alternator excitation
- Electronic leakage relay
- Isometer
- Volt adjustable from control panel
- Deadening kit
- Plug-in board with RS232 & RS485 output for RTU Modbus protocol
- Ethernet plug-in board with RJ45 output for TCP/IP Modbus protocol - SNMP Modbus - Internet
- Plug-in board with integrated GSM/GPRS Modem for Gen-set remote control via SMS or Internet