

# GENERATING SET GE 6500 YDT

The images are for reference



## FEATURES

- Manual recoil
- Output sockets: 1x 400V 16A 3P+N +T CEE  
1x 230V 16A 2P+T CEE
- Circuit breaker
- Protective frame
- Portable
- Not compliant with noise directive 2000/14/EC



Air cooling



diesel



three-phase



manual recoil

## POWER RATINGS

* Stand-by three-phase power	6.5 kVA (5.2 kW) / 400V / 9.3A
* PRP three-phase power	5.7 kVA (4.6 kW) / 400V / 8.2A
* PRP single-phase power	4 kVA / 230V / 17.3A
* COP three-phase power	/
Frequency	50 Hz
Cos φ	0.8

\* Output powers according to ISO 8528

## DEFINITIONS

Valid declared powers up to the followings environmental conditions: temperature 25°C, altitude 100 meters above sea level)

**LTP stand-by power:** Maximum available power for use with variable loads for a yearly number of hours limited at 500 h. No overload is admitted.

**PRP power:** Continue power with variable loads. Maximum power for use with variable loads for a yearly unlimited numbers of hours.

**COP power:** COP Power: continuous power with constant load. Maximum power for use with constant loads for a yearly unlimited numbers of hours.

## 3000 RPM ENGINE

### 4-STROKE, DIRECT INJECTION, NATURAL ASPIRATED

Model	YANMAR L 100
* Stand-By net power	6.3 kWm (8.5 hp)
* PRP net power	5.7 kWm (7.7 hp)
* COP net power	/
Cylinders/ Displacement	1 / 435 cm <sup>3</sup> (0.435 lt.)
Bore / Stroke	86 / 75 (mm)
Compression ratio	20 : 1
BMEP (Brake Mean Effective Pressure : LTP - PRP)	/
Speed governor type	Mechanical
<b>FUEL CONSUMPTION</b>	
110 % (Stand-By power)	200 g/kWh - 1.5 lt./h
100 % of PRP	200 g/kWh - 1.3 lt./h
75 % of PRP	200 g/kWh - 1 lt./h
50 % of PRP	220 g/kWh - 0.75 lt./h
<b>COOLING SYSTEM</b>	
Total system cap. - only engine	/
Fan air flow	/
<b>LUBRIFICATION SYSTEM</b>	
Total oil system capacity	/
Oil capacity in sump	1.6 lt.
Oil consumption at full load	/

\* Output powers according to ISO 3046-1

## EXHAUST SYSTEM

Maximum exhaust gas flow	/
Max. exhaust gas temp.	/
Maximum back pressure	3.3 kPa (0.033 bar - 330 mmH <sub>2</sub> O)
External diameter exhaust pipe	/
<b>ELECTRICAL SYSTEM</b>	
Starter motor power	/
Battery charging alternator cap.	/
Cold star	0°C
Cold start aids	/
<b>AIR FILTER</b>	
Combustion air flow	/
<b>HEAT REJECTED AT FULL LOAD</b>	
To exhaust system	/
To water and oil	/
Radiated to room	/
To charge cooler	/



## ALTERNATOR

### SYNCHRONOUS, THREE-PHASE, SELF-EXCITED, SELF-REGULATED

Continuous power	7 kVA
Stand-By power	7.7 kVA
Tensione three-phase	400 Vac
Frequency	50 Hz
Cos φ	0.8
Model A.V.R.	/
Voltage regulation acc	± 4 %
Sustained short circuit current	3 In
Transient dip (100% load)	< 15 %
Recovery time	/
Efficiency at 100% load	80.5 % (400V - Cos φ 1)
Insulation	Class H
Connection - Terminals	Stella - N°6
Electromagnetic compatibility ( R.F.I. suppr.)	EN55011
Waveform distorsion - THD	< 4 %
Telephone interference - THF	/

### REACTANCES (7 KVA - 400 V)

Direct axis synchronuos - Xd	270 %
Direct axis transient - X'd	20 %
Direct axis subtransient - X''d	6.5 %
Quadrature axis synchronuos. - Xq	150 %
Quadr. axis subtransient - X''q	/
Negative sequence - X2	/
Zero sequence - X0	/
<b>TIME CONSTANTS</b>	
Transient - T'd	33 ms
Subtransient - T''d	5.5 ms
Open circuit - T'do	450ms
Armature - Ta	/
Short-circuit ratio Kcc	0.60
IP protection degree	IP 23
Cooling air flow	0.062/ m³/sec
Coupling - Bearing	Direct J609b - N°1

## GENERAL SPECIFICATION

Tank capacity	5.5 lt.
Running time (75% of PRP)	5.5 h
Start battery	/
IP protection degree	IP 23

* Measured acoustic power LwA (pressure LpA)	99 dB(A) (74 dB(A) @ 7m)
Performance class	G2

\* Acoustic power according to European Directive 2000/14/CE

## CONTROL PANEL

- Output sockets: 1x 400V 16A 3P+N +T CEE  
1x 230V 16A 2P+T CEE
- Voltmeter
- Circuit breaker
- Earth terminal (PE)



# WEIGHT - DIMENSIONS AND ACCESSORIES

GE 6500 YDT



### DRY WEIGHT OF MACHINE:

- 97 kg

Generating set pictured may include optional accessories.



### DIMENSIONS PICTURE

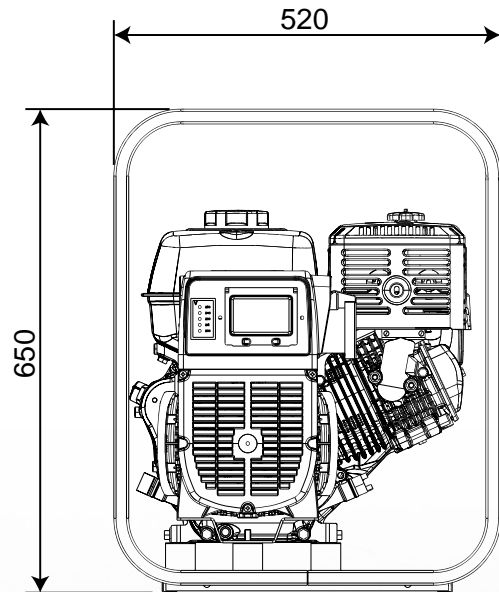
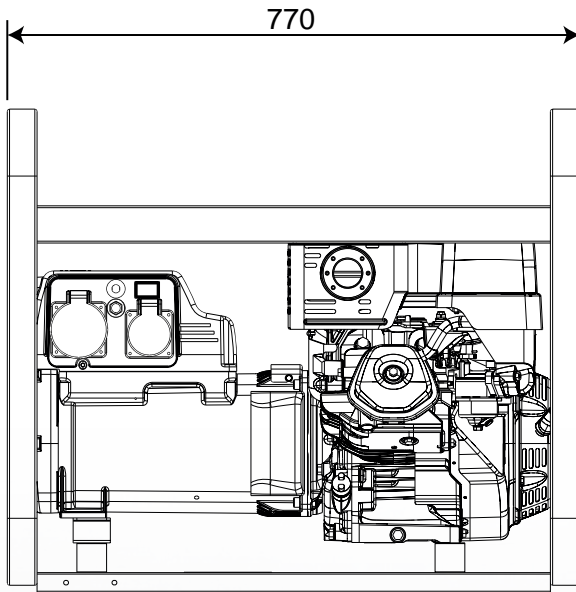

### OPTIONS ON REQUEST

- Earthing kit
- Moving trolley CM8



### VERSIONS ON REQUEST

- /



### FACTORY INSTALLATION OPTIONS

- ELCB-GFI (Ground Fault Interruptor)

## GENERAL INFORMATION

### COMPLIANCE GENERATING SETS WITH EC DIRECTIVES AND STANDARDS

- 2006/42 / EC (Machines Directive)
- 2014/35 / EU (Low Voltage Directive)
- 2014/30 / EU (EMC Directive)
- ISO 8528 (Reciprocating internal combustion engine driven alternating current generating sets)



ISO 9001:2008 - Cert. 0192

### WARRANTY

All devices are covered by the manufacturer's warranty.

Non-contractual document. Specification subject to change without notice.

© MOSA - Viale Europa, 59 - 20047 Cusago (Milano) - Italy - phone +39-0290352.1 - fax + 39-0290390466 E-mail: export@mosa.it Web site: www.mosa.it

