



# GENERATING SET GE 35 KSC

The images are for reference



## FEATURES

- Automatic voltage regulation AVR
- The rounded edges of the canopy designed for rainwater drainage away
- Bunded base suitable to contain any liquids leakage from engine avoiding environmental pollution
- External caps for oil and water drain
- Engine cowling side, can be completely opened, which facilitates all maintenance operations
- Central lifting eye
- Control panel with digital control unit
- The forklifts handling is possible from all sides
- Meets EC directives for noise and safety



water cooled



diesel



three-phase power



electric



silenced

POWER RATINGS	
* Stand-By three-phase power	33 kVA (26.4 kW) / 400V / 47.6 A
* PRP three-phase power	30 kVA (24 kW) / 400V / 43.3 A
* PRP single-phase power	11 kVA / 230V / 47.8 A
* COP three-phase power	/
Frequency	50 Hz
Cos φ	0.8

\* Output powers according to ISO 8528-1

## DEFINITION

**Valid declared powers up to the followings environmental conditions: temperature 25°C, altitude 100 meters above sea level**

**LTP power: stand-by power:** Maximum available power for use with variable loads for a yearly number of hours limited at 500 h. No overload is admitted.

**PRP power:** continue power with variable loads. Maximum power for use with variable loads for a yearly illimited nubers of hours.

**COP power:** continuous power with constant load. Maximum power for use with constant loads for a yearly unlimited numbers of hours.

## ENGINE 1500 RPM

4 STROKE, DIRECT INJECTION, NATURAL ASPIRATED	
Model	KOHLER - KDI 2504TM-30
* Stand-By net power	31,1 kW (42,3 hp)
* PRP net power	28.2 kW (38.3 hp)
* COP net power	/
Cylinders / Displacement	4 / 2482 cm <sup>3</sup> (2.482 lt.)
Bore / Stroke	88 / 102 (mm)
Compression ratio	18.5 : 1
BMEP (Brake Mean Effective Pressure : LTP - PRP)	940 kPa
Speed governor type	Mechanical
<b>FUEL CONSUMPTION</b>	
110 % (Stand-by power)	8.3 lt./h
100 % to PRP	7.5 lt./h
75 % to PRP	5.7 lt./h
50 % to PRP	4 lt./h
<b>COOLING SYSTEM</b>	
Total system cap. - only engine	9.1 lt
Fan air flow	70.8 m <sup>3</sup> /min
<b>LUBRICATION SYSTEM</b>	
Total oil system capacity	/
Oil capacity in sump	11.2 lt.
Oil consumption at full load	< 0.017 l/h

\* Output powers according to ISO 3046-1

EXHAUST SYSTEM	
Maximum exhaust gas flow	6.2 lt./mim.
Max. exhaust gas temp.	455 °C
Maximum back pressure	8 kPa (0.08 bar)
External diameter exhaust pipe	/
<b>ELECTRICAL SYSTEM</b>	
Starter motor power	2.2 kW
Battery charging alternator cap.	55 A
Cold start	-10°C
With cold start aid	- 15 °C
<b>AIR FILTER</b>	
Combustion air flow	2 m <sup>3</sup> /min
<b>HEAT REJECTED AT FULL LOAD</b>	
To exhaust system	/
To water and oil	/
Radiated to room	/
To charge cooler	/



## ALTERNATOR

### SYNCHRONOUS, THREE-PHASE, SELF-EXCITED, SELF-REGULATED, BRUSHLESS

Continuous power	30 kVA
Stand-by power	33 kVA
Three phase voltage	380-415 Vac
Frequency	50 Hz
Cos φ	0.8
Model A.V.R.	HVR-11
Voltage regulation acc.	± 1.0 %
Sustained short circuit current	2.5 I <sub>n</sub>
Transient dip (100% load)	10 %
Recovery time	≤ 3 sec.
Efficiency at 100% load	87.1 % (400V - Cos φ 0.8)
Insulation	Class H
Connection - Terminals	Star - N°6
Electromagnetic compatibility (R.F.I. suppr.)	EN 55011
Waveform distortion - THD	< 3 %
Telephone interference - THF	/

### REACTANCES (30 kVA - 400V)

Direct axis synchronous - X <sub>d</sub>	243 %
Direct axis transient - X' <sub>d</sub>	19 %
Subdirect axis transient - X'' <sub>d</sub>	8 %
Quadrature axis synchronous - X <sub>q</sub>	135 %
Quadr. axis subtransient - X'' <sub>q</sub>	/
Negative sequence - X <sub>2</sub>	/
Zero sequence - X <sub>0</sub>	/
<b>TIME CONSTANTS</b>	
Transient - T' <sub>d</sub>	0.01 sec
Subtransient - T'' <sub>d</sub>	0.005 sec
Open circuit - T' <sub>do</sub>	0.125 sec
Armature - T <sub>a</sub>	/
Short-circuit ratio K <sub>cc</sub>	0.58
IP protection degree	IP 23
Cooling air flow	0.115 m <sup>3</sup> /sec.
Coupling   Bearing	Direct SAE 3 - 11.5 ½ - N°1

## GENERAL SPECIFICATIONS

Fuel tank capacity	55 lt.
Running time (75% to PRP)	9.6 h
Starter battery	12 Vdc -80Ah / 670A CCA(EN)
IP protection degree	IP 23

* Measured acoustic power L <sub>WA</sub> (pressure L <sub>pA</sub> )	92.7 dB(A) (67.7 dB(A) @ 7m)
* Guaranteed acoustic power L <sub>WA</sub> (pressure L <sub>pA</sub> )	94 dB(A) (69 dB(A) @ 7m)
Performance class (ISO 8528)	G2

\* Acoustic power according to European Directive 2000/14/CE

# CONTROL PANEL

## AUTOMATIC CONTROL PANEL

- Controller IntelliNano Plus
- Controller supply switch
- Battery charge warning light fault
- Emergency stop button
- TCM 35 remote control plug
- Connection terminal-board PAC (ATS) (Automatic control panel only)
- Battery charger (Automatic control panel only)
- Circuit breaker - ELCB-GFI (Ground Fault Interruptor)
- Circuit breaker
- Power terminal-board
- Earth terminal (PE)



INTELINANO PLUS CONTROLLER CHARACTERISTICS	
Operating mode	<ul style="list-style-type: none"> <li>• MAN.- AUTO</li> </ul>
Display	<ul style="list-style-type: none"> <li>• Graphic back-light LCD display 128x64 pixels</li> </ul>
LEDs	<ul style="list-style-type: none"> <li>• Engine operation</li> <li>• AUTO operating mode</li> <li>• Alarm</li> </ul>
Buttons	<ul style="list-style-type: none"> <li>• START button</li> <li>• STOP button</li> <li>• AUTO button</li> <li>• N° 2 buttons for controller programming</li> </ul>
Generator Measures	<ul style="list-style-type: none"> <li>• Voltage : L1-L2/L2-L3/L3-L1/N-L1/N-L2/N-L3</li> <li>• Voltage : L1-L2 (Automatic control panel only)</li> <li>• Current : I1</li> <li>• Powers : kVA</li> <li>• Frequency</li> </ul>
Engine Measures	<ul style="list-style-type: none"> <li>• Water temperature (optional)</li> <li>• Oil pressure (optional)</li> <li>• Fuel level</li> <li>• Rpm meter</li> <li>• Battery voltage</li> <li>• Maintenance</li> <li>• Hours meter</li> </ul>
Generator Protections	<ul style="list-style-type: none"> <li>• Short circuit</li> <li>• Over-Undervoltage</li> <li>• Over-Underfrequency</li> <li>• Phase sequence (Automatic control panel only)</li> </ul>

Engine Protections	<ul style="list-style-type: none"> <li>• Overspeed</li> <li>• High water temperature alarm</li> <li>• High water temperature warning</li> <li>• Low oil pressure warning</li> <li>• Low fuel level warning</li> <li>• Under battery voltage</li> <li>• Battery charge alternator failure</li> <li>• Start failure</li> <li>• Stop failure</li> <li>• Emergency stop</li> </ul>
AMF functions (Automatic control panel only)	<ul style="list-style-type: none"> <li>• Measure mains voltage : L1-L2 / L2-L3 / L3-L1 - N-L1 / N-L2 / N-L3</li> <li>• Measure mains frequency</li> <li>• Three phase detection</li> <li>• Over-Under mains voltage</li> <li>• Over-Under mains frequency</li> <li>• Phase sequence</li> </ul>
Features	<ul style="list-style-type: none"> <li>• Event log and alarms (10 events)</li> <li>• Operator interface with icons, no text</li> <li>• Remote Start and Stop</li> <li>• Pre-heating</li> <li>• Fully programmable from the panel or from PC</li> <li>• Direct connection to engines with ECU via Can bus J1939</li> <li>• Manual operation (MRS) with remote start</li> <li>• IP65 protection</li> <li>• Operation temperature: -20°C / +70°C</li> </ul>
Communication	<ul style="list-style-type: none"> <li>• Setup USB port</li> <li>• CAN BUS interface (J1939 only)</li> </ul>

## MANUAL CONTROL PANEL WITH SOCKETS

- Supply switch
- Siren
- Battery charge warning light fault
- Emergency stop button
- TCM 35 remote control plug
- Circuit breaker
- Earth leakage circuit breaker (GFI)
- Output sockets: 1x 400V 63A 3P+N+T CEE
  - 1x 400V 32A 3P+N+T CEE
  - 1x 400V 16A 3P+N+T CEE
  - 1x 230V 16A 2P+T CEE
  - 1x 230V 16A 2P+T SCHUKO
- Circuit breaker for 400V 32A socket
- Circuit breaker for 400V 16A socket
- Circuit breaker for 230V 16A sockets
- Earth terminal (PE)

# WEIGHT - DIMENSIONS AND ACCESSORIES

GE 35 KSC



### DRY WEIGHT MACHINE:

- 847 Kg

Generating set pictured may include optional accessories.



### DIMENSIONS DRAW

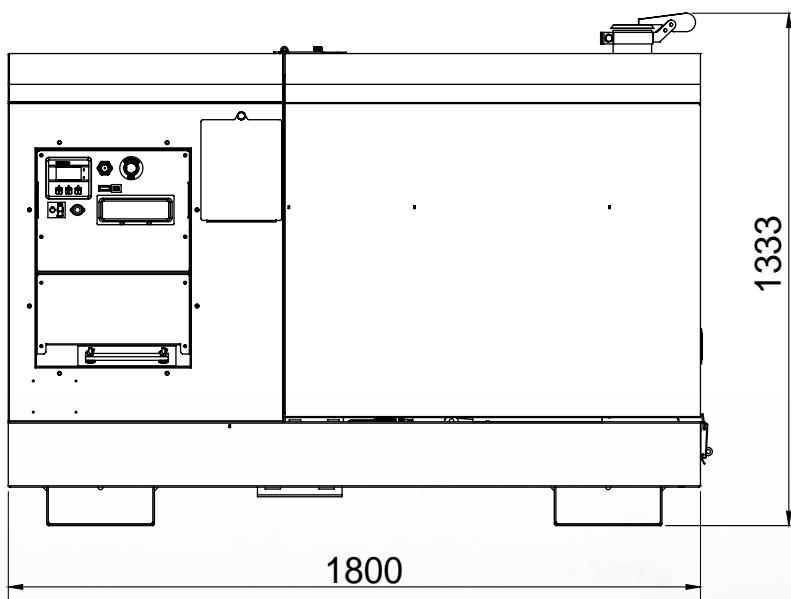
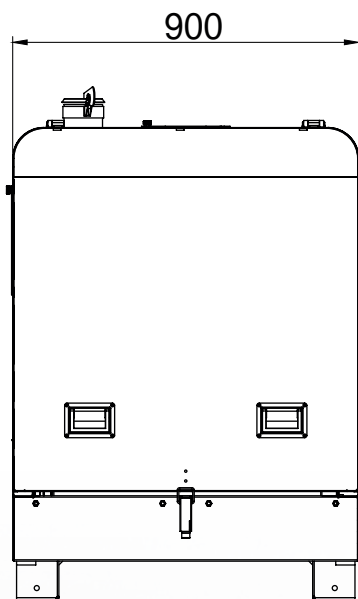

### OPTIONS ON REQUEST

- Load transfer switch (ATS) PAC 42 (60A) (Only with Automatic control panel)
- Load transfer switch (ATS) PAC-I 42 (60A) (Only with Manual control panels)
- Remote control TCM35
- Site tow CTL30
- Road trailer CTV1
- Earthing kit



### VERSIONS ON REQUEST

- Manual digital control panel with sockets CEE and SCHUKO
- Digital control panel (without sockets)



### FACTORY INSTALLATION OPTIONS

- Gauges - water temperature and oil pressure
- Earth leakage relay
- Radio control
- Main battery switch
- Engine water heater
- 100 litre internal tank

## GENERAL INFORMATION

### COMPLIANCE GENERATING SETS WITH EC DIRECTIVES AND STANDARDS

- 2006/42 / EC (Machines Directive)
- 2014/35 / EU (Low Voltage Directive)
- 2014/30 / EU (EMC Directive)
- 2000/14 / EC (Directive Acoustic Emission for machines for use outdoors)
- ISO 8528 (Reciprocating internal combustion engine driven alternating current generating sets)



ISO 9001:2008 - Cert. 0192

### WARRANTY

All devices are covered by the manufacturer's warranty.

The company reserves the right to change this specification without notice. For further information please contact the sales department.

© MOSA - Viale Europa, 59 - 20090 Cusago (Milano) - Italy - phone +39-0290352.1 - fax + 39-0290390466 E-mail: info@mosa.it Web site: www.mosa.it

