

GENERATING SET GE 15000 HBM

The images are for reference



FEATURES

- Honda iGX engine with electronic speed control
- Electronic injection
- Automatic Starter (Auto- Choke)
- Auto-Idle function on request
- Multifunction digital instrument: V-Hz-h
- Electronic voltage regulation "AVR"
- Circuit breaker
- ELCB-GFI (Ground Fault Interruptor)
- Not compliant with noise directive 2000/14/EC



air cooled



petrol



single-phase
power



electric start



POWER RATINGS

* Stand-By single-phase power (LTP)	14 kVA (12.6 kW) / 230V / 60.9A
* PRP single-phase power	12.5 kVA (11.2 kW) / 230V / 54.3A
Frequency	50 Hz
Cos φ	0.9

* Output powers according to ISO 8528-1

DEFINITION

Valid declared powers up to the followings environmental conditions: temperature 25°C, altitude 100 meters above sea level)

LTP power: stand-by power: Maximum available power for use with variable loads for a yearly number of hours limited at 500 h. No overload is admitted.

PRP power: continue power with variable loads. Maximum power for use with variable loads for a yearly illimited nubers of hours.

COP power: continuous power with constant load. Maximum power for use with constant loads for a yearly unlimited numbers of hours.

ENGINE 3000 RPM

4 STROKE OHV, NATURAL ASPIRATED

Model	HONDA iGX 800
* Stand-By net power	16.8 kWm (22.8 hp)
* PRP net power	13.3 kWm (18 hp)
* COP net power	/
Cylinders / Displacement	2 a V / 779 cm ³ (0.779 lt.)
Bore / Stroke	83 / 72 (mm)
Compression ratio	9.1 : 1
BMEP (Brake Mean Effective Pressure : LTP - PRP)	/
Speed governor type	Electronic
FUEL CONSUMPTION	
110 % (Stand-by power)	6.9 lt./h
100 % to PRP	6.3 lt./h
75 % to PRP	4.7 lt./h
50 % to PRP	3.2 lt./h
COOLING SYSTEM	
Total system cap. - only engine	/
Fan air flow	/
LUBRICATION SYSTEM	
Total oil system capacity	/
Oil capacity in sump	2 lt.
Oil consumption at full load	/

EXHAUST SYSTEM

Maximum exhaust gas flow	/
Max. exhaust gas temp.	/
Maximum back pressure	/
External diameter exhaust pipe	/
ELECTRICAL SYSTEM	
Starter motor power	/
Battery charging alternator cap.	20 A
Cold start	/
With cold start aid	/
AIR FILTER	
Combustion air flow	/
HEAT REJECTED AT FULL LOAD	
To exhaust system	/
To water and oil	/
Radiated to room	/
To charge cooler	/

ALTERNATOR

SYNCHRONOUS, SINGLE-PHASE, SELF-EXCITED, SELF-REGULATED	
Continuous power	12.5 kVA
Stand-by power	14 kVA
Single phase voltage	220-240 Vac
Frequency	50 Hz
Cos φ	0.9
Model A.V.R.	AVR960D
Voltage regulation acc.	± 2 %
Sustained short circuit current	≤ 4 In
Transient dip (100% load)	< 15 %
Recovery time	/
Efficiency at 100% load	82 % (230V - Cos φ 1)
Insulation	Class H
Connection - Terminals	Series - N°4
Electromagnetic compatibility (R.F.I. suppr.)	/
Waveform distortion - THD	< 6%
Telephone interference - THF	/

REACTANCES (12.5 KVA - 230 V)	
Direct axis synchronous - Xd	/
Direct axis transient - X'd	/
Subdirect axis transient - X''d	/
Quadrature axis synchronous - Xq	/
Quadr. axis subtransient - X''q	/
Negative sequence - X2	/
Zero sequence - X0	/
TIME CONSTANTS	
Transient - T'd	/
Subtransient - T''d	/
Open circuit - T'do	/
Armature - Ta	/
Short-circuit ratio Kcc	/
IP protection degree	IP 23
Cooling air flow	/
Coupling Bearing	Direct - N°1

GENERAL SPECIFICATIONS

Fuel tank capacity	18 lt.
Running time (75% to PRP)	3.8 h
Starter battery	12 Vdc -37Ah / 330A CCA(EN)

IP protection degree	IP 23
Acoustic power LwA (pressure LpA)	99 dB(A) (74 dB(A) @ 7m)
Performance class (ISO 8528)	G2

CONTROL PANEL

- Starter key
- Oil alert warning light (led)
- Hour meter
- Fuel tap
- Auto-Idle switch (only for version with Auto Idle)
- Multifunction digital instrument: Voltmeter / Frequency meter / Total hour counter / Partial hour meter (resettable)
- Circuit breaker
- ELCB-GFI (Ground Fault Interruptor)
- Magnetothermic switch for 230V 32A socket
- Magnetothermic switch for 230V 16A sockets
- Output sockets: 1x 230V 32A 2P+T CEE
2x 230V 16A 2P+T CEE
- Earth terminal (PE)



AUTOIDLE FUNCTION (OPTIONAL)

Usually petrol gensets are operating at high speed, 3000 rpm.

Experience has taught us that during their use, gensets very often operate with no load. This operation inevitably causes greater fuel consumption and therefore greater environmental pollution and greater noise in the working area.

With **AUTOIDLE** function all this is eliminated, as the engine runs at a low rpm, consequently lower fuel consumption and less noise, and only when current load is requested it automatically goes to the nominal rpm without delays and for any type of load.

WEIGHT - DIMENSIONS AND ACCESSORIES

GE 15000 HBM



DRY WEIGHT MACHINE:

- 152 Kg

Generating set pictured may include optional accessories.



DIMENSIONS DRAW (mm)

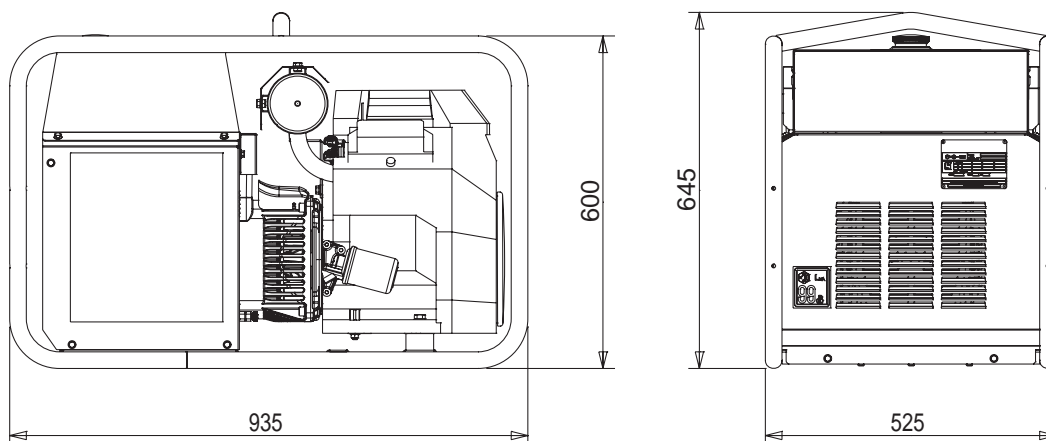

VERSIONS IN ADDITION TO THE SERIES FEATURES

AUTO IDLE

- Auto Idle

OPTIONS ON REQUEST

- Earthing
- Trolley CTM 10
- Tank cap with lock

AVAILABLE VERSION

CL5L6001	230V - HONDA iGX800 1x230V 32A CEE - 2x230V 16A CEE
CL5L6011	230V SCHUKO - HONDA iGX800 1x230V 32A CEE - 2x230V 16A SCHUKO
CL5L6001Z	AUTO IDLE - HONDA iGX800 230M 1x230V 32A CEE - 2x230V 16A CEE
CL5L6011Z	SCHUKO AUTO IDLE - HONDA iGX800 230M 1x230V 32A CEE - 2x230V 16A SCHUKO

GENERAL INFORMATION

COMPLIANCE GENERATING SETS WITH EC DIRECTIVES AND STANDARDS

2006/42 / EC (Machines Directive)
2014/35 / EU (Low Voltage Directive)
2014/30 / EU (EMC Directive)
ISO 8528 (Reciprocating internal combustion engine driven alternating current generating sets)



ISO 9001:2008 - Cert. 0192

WARRANTY

All devices are covered by the manufacturer's warranty.

Non-contractual document. Specification subject to change without notice.

© MOSA - Viale Europa, 59 - 20047 Cusago (Milano) - Italy - phone +39-0290352.1 - fax + 39-0290390466 E-mail: export@mosa.it Web site: www.mosa.it

