

TS 200 DS-DES/CF

0 2 1 1

272709003 - GB

USE AND MAINTENANCE MANUAL SPARE PARTS CATALOG

The TS 200 engine driven welder is a unit which ensures the function as:

- a) a current source for arc welding
- b) a current source for the auxiliary generation

Unit meant for industrial and professional use, powered by an endothermic engine; it is composed of various main parts such as: engine, alternator, electric and electronic controls, the fairing or a protective structure. The assembling is made on a steel structure, on which are provided elastic support which must damp the vibrations and also eliminate sounds which would produce noise.

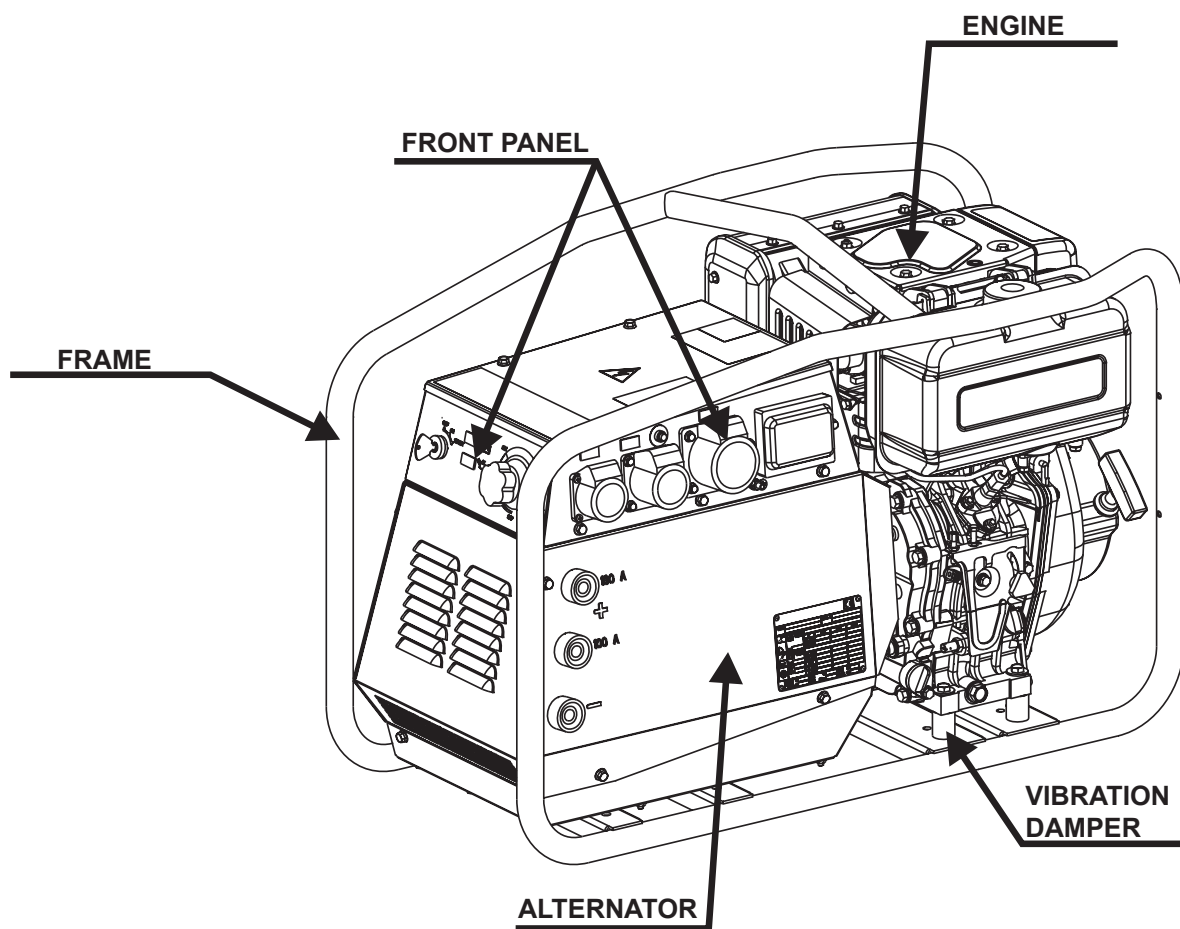



UNI EN ISO 9001 : 2008

ISO 9001:2008 - Cert. 0192

MOSA has certified its quality system according to UNI EN ISO 9001:2008 to ensure a constant, high quality of its products. This certification covers the design, production and servicing of engine driven welders and generating sets.

The certifying institute, ICIM, which is a member of the International Certification Network IQNet, awarded the official approval to MOSA after an examination of its operations at the head office and plant in Cusago (MI), Italy.

This certification is not a point of arrival but a pledge on the part of the entire company to maintain a level of quality of both its products and services which will continue to satisfy the needs of its clients, as well as to improve the transparency and the communications regarding all the company's activities in accordance with the official procedures and in harmony with the MOSA Manual of Quality.

The advantages for MOSA clients are:

- Constant quality of products and services at the highest level which the client expects;
- Continuous efforts to improve the products and their performance at competitive conditions;
- Competent support in the solution of problems;
- Information and training in the correct application and use of the products to assure the security of the operator and protect the environment;
- Regular inspections by ICIM to confirm that the requirements of the company's quality system and ISO 9001 are being respected.

All these advantages are guaranteed by the CERTIFICATE OF QUALITY SYSTEM No.0192 issued by ICIM S.p.A. - Milano (Italy) - www.icim.it

M 01	QUALITY SYSTEM
M 1.01	COPYRIGHT
M 1.1	NOTES
M 1.4	MARCHIO CE
M 1.5	DATI TECNICI
M 2 - ...	SYMBOLS AND SAFETY PRECAUTIONS
M 2.5 -....	INSTALLATION AND ADVICE BEFORE USE
M 2.6	INSTALLATION AND ADVICE
M 2.7	INSTALLATION
M 3	UNPACKING
M 4.1	TRANSPORT AND DISPLACEMENTS
M 6.5	ASSEMBLY: CTM 6/2 - PB3
M 20	SET-UP FOR OPERATION
M 21	STARTING THE ENGINE
M 22	STOPPING THE ENGINE
M 31	CONTROLS
M 34	USE AS A WELDER
M 37	USE AS A GENERATOR
M 39.6	ENGINE PROTECTION
M 40.1	TROUBLE SHOOTING
M 43...	MAINTENANCE
M 45	STORAGE
M 46	CUST OFF
M 53	DIMENSIONS
M 55	RECOMMENDED ELECTRODES
M 60	ELECTRICAL SYSTEM LEGEND
M 61-.....	ELECTRICAL SYSTEM
R 1	SPARE PARTS TABLES
DR ...	SPARE PARTS



ATTENTION

This use and maintenance manual is an important part of the machines in question.

The assistance and maintenance personnel must keep said manual at disposal, as well as that for the engine and alternator (if the machine is synchronous) and all other documentation about the machine.

We advise you to pay attention to the pages concerning the security (see page M1.1).



© All rights are reserved to said Company.

It is a property logo of MOSA division of B.C.S. S.p.A. All other possible logos contained in the documentation are registered by the respective owners.

▄▄▄▄▶ The reproduction and total or partial use, in any form and/or with any means, of the documentation is allowed to nobody without a written permission by MOSA division of B.C.S. S.p.A.

To this aim is reminded the protection of the author's right and the rights connected to the creation and design for communication, as provided by the laws in force in the matter.

In no case MOSA division of B.C.S. S.p.A. will be held responsible for any damage, direct or indirect, in relation with the use of the given information.

MOSA division of B.C.S. S.p.A. does not take any responsibility about the shown information on firms or individuals, but keeps the right to refuse services or information publication which it judges discutible, unright or illegal.

INFORMATION

Dear Customer,
We wish to thank you for having bought from MOSA a high quality set.

Our sections for Technical Service and Spare Parts will work at best to help you if it were necessary.

To this purpose we advise you, for all control and overhaul operations, to turn to the nearest authorized Service Centre, where you will obtain a prompt and specialized intervention.

- ☞ In case you do not profit on these Services and some parts are replaced, please ask and be sure that are used exclusively original MOSA parts; this to guarantee that the performances and the initial safety prescribed by the norms in force are re-established.
- ☞ **The use of non original spare parts will cancel immediately any guarantee and Technical Service obligation from MOSA.**

NOTES ABOUT THE MANUAL

Before actioning the machine please read this manual attentively. Follow the instructions contained in it, in this way you will avoid inconveniences due to negligence, mistakes or incorrect maintenance. The manual is for qualified personnel, who knows the rules: about safety and health, installation and use of sets movable as well as fixed.

You must remember that, in case you have difficulties for use or installation or others, our Technical Service is always at your disposal for explanations or interventions.

The manual for Use Maintenance and Spare Parts is an integrant part of the product. It must be kept with care during all the life of the product.

In case the machine and/or the set should be yielded to another user, this manual must also given to him.

Do not damage it, do not take parts away, do not tear pages and keep it in places protected from dampness and heat.

You must take into account that some figures contained in it want only to identify the described parts and therefore might not correspond to the machine in your possession.

INFORMATION OF GENERAL TYPE

In the envelope given together with the machine and/or set you will find: the manual for Use Maintenance and Spare Parts, the manual for use of the engine and the tools (if included in the equipment), the guarantee (in the countries where it is prescribed by law).

Our products have been designed for the use of generation for welding, electric and hydraulic system; ANY OTHER DIFFERENT USE NOT INCLUDED IN THE ONE INDICATED, relieves MOSA from the risks which could happen or, anyway, from that which was agreed when selling the machine; MOSA excludes any responsibility for damages to the machine, to the things or to persons in this case.

Our products are made in conformity with the safety norms in force, for which it is advisable to use all these devices or information so that the use does not bring damage to persons or things.

While working it is advisable to keep to the personal safety norms in force in the countries to which the product is destined (clothing, work tools, etc.).

Do not modify for any motive parts of the machine (fastenings, holes, electric or mechanical devices, others..) if not duly authorized in writing by MOSA: the responsibility coming from any potential intervention will fall on the executioner as in fact he becomes maker of the machine.

- ☞ **Notice:** *this manual does not engage MOSA, who keeps the faculty, apart the essential characteristics of the model here described and illustrated, to bring betterments and modifications to parts and accessories, without putting this manual uptodate immediately.*









Any of our product is labelled with CE marking attesting its conformity to applicable directives and also the fulfillment of safety requirements of the product itself; the list of these directives is part of the declaration of conformity included in any machine standard equipment.

Here below the adopted symbol:



CE marking is clearly readable and unerasable and it can be either part of the data-plate.

MOSA		V.le Europa, 59-20090 CUSAGO (MI) ITALY	
		tel. +39-0290352.1 fax. +39-0290390466	
		http://www.mosa.it e-mail: info@mosa.it	
	Made in UE-ITALY	TYPE	
		SERIAL N°	
		X	
		I ₂ (A)	
U ₀		U ₂ (V)	
		I ₂ (A)	
		U ₂ (V)	
Hz		kVA	
P.F.		V (V)	
		I (A)	
	n	RPM	n ₁
	n ₀	RPM	P _{max}
		KW	I. CL.
			IP

MOSA		V.le Europa, 59-20090 CUSAGO (MI) ITALY	
		tel. +39-0290352.1 fax. +39-0290390466	
		http://www.mosa.it e-mail: info@mosa.it	
	Made in UE-ITALY	TYPE	
		SERIAL N°	
		Generating Set ISO 8528	
KVA			
V			
I			
Hz		P.F.	LTP POWER IN ACCORDANCE WITH ISO 8528
RPM		I. CL.	IP
ALTIT.	100 m	TEMP.	25 °C
			MASS

Furthermore, on each model it is shown the noise level value; the symbol used is the following:

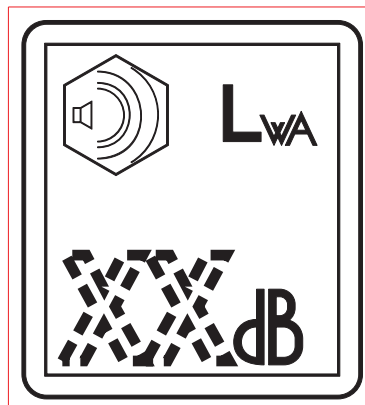

The indication is shown in a clear, readable and indeleble way on a sticker.

BCS S.p.A.Sede legale:
Via Marradi 1
20123 Milano - Italia**Stabilimento di Cusago, 20090 (MI) - Italia**V.le Europa 59
Tel.: +39 02 903521
Fax: +39 02 90390466

ISO 9001:2000 - Cert. 0192

DICHIARAZIONE DI CONFORMITA'Déclaration de Conformité – Declaration of Conformity – Konformitätserklärung
Conformiteitsverklaring – Declaración de Conformidad

BCS S.p.A. dichiara sotto la propria responsabilità che la macchina:
BCS S.p.A. déclare, sous sa propre responsabilité, que la machine:
BCS S.p.A. declares, under its own responsibility, that the machine:
BCS S.p.A. erklärt, daß die Aggregate:
BCS S.p.A. verklaard, onder haar eigen verantwoordelijkheid, dat de machine:
BCS S.p.A. declara bajo su responsabilidad que la máquina:

GRUPPO ELETTROGENO DI SALDATURA / WELDING GENERATOR GRUPPO ELETTROGENO / POWER GENERATOR

Marchio / Brand : MOSA

Modello / Model :

Matricola / Serial number :

è conforme con quanto previsto dalle Direttive Comunitarie e relative modifiche:
est en conformité avec ce qui est prévu par les Directives Communautaires et relatives modifications:
conforms with the Community Directives and related modifications:
mit den Vorschriften der Gemeinschaft und deren Ergänzungen übereinstimmt:
in overeenkomst is met de inhoud van gemeenschapsrichtlijnen gerelateerde modificaties:
comple con los requisitos de la Directiva Comunitaria y sus anexos:

2006/42/CE - 2006/95/CE - 2004/108/CE

Nome e indirizzo della persona autorizzata a costituire il fascicolo tecnico :

Nom et adresse de la personne autorisée à composer le Dossier Technique :

Person authorized to compile the technical file and address :

Name und Adresse der zur Ausfüllung der technischen Akten ermächtigten Person :

Persoon bevoegd om het technische document, en bedrijf gegevens in te vullen

Nombre y dirección de la persona autorizada a componer el expediente técnico :

ing. Benso Marelli - Amministratore Delegato / CEO; V.le Europa 59, 20090 Cusago (MI) - Italy

Cusago,

Ing. Benso Marelli
Amministratore Delegato
CEO

Technical data	TS 200 DS/CF	TS 200 DES/CF
D.C. WELDING C.C.		
Duty cycle	190A/35% - 160A/60% - 120A/100%	
Welding current regulation (I scale)	20 - 100A	
(II scale)	90 - 190A	
Welding voltage	98V	
Welding voltage	20-27V	
GENERATOR		
Three-phase generation	6 kVA / 400 V / 8.7 A	
Single-phase generation	5 kVA / 230 V / 21.7 A	
Single-phase generation	2.5 kVA / 110 V / 22.7 A	
Single-phase generation	2 kVA / 48 V / 41.6 A	
Frequency	50 Hz	
Cos φ	0.8	
ALTERNATOR	Self-excited, self-regulated, brushless	Self-excited, self-regulated
Type	three-phase, asynchronous	
Insulating class	H	
ENGINE		
Mark / Model	Yanmar / L 100 N	
Type / Cooling system	Diesel 4-Stroke / air	
Cylinders / Displacement	1 / 435 cm ³	
Output	6.5 kW (8.8 HP)	
Speed	3000 rpm	
Fuel consumption (Welding 60%)	1 l/h	
Engine oil capacity	1.6 l	
Starter	recoil	electric
GENERAL SPECIFICATIONS		
Tank capacity	5.5 l	
Running time (Welding 60%)	5.5 h	
Protection	IP 23	
*Dimensions Lxwxh (mm)	900x550x622	
*Weight	130 Kg	131 Kg
**Acoustic power LwA (pressure LpA)	99 LWA (74 dB(A) - 7 m)	
*Dimensions and weight are inclusive of all parts without wheels and towbar CTM. - ** For fixed installation only		

POWER

Declared power according to ISO 3046-1 (temperature 25°C, 30% relative humidity, altitude 100 m above sea level).

It's admitted overload of 10% each hour every 12 h.

In an **approximative** way one reduces: of 1% every 100 m altitude and of 2.5% for every 5°C above 25°C.

ACOUSTIC POWER LEVEL

ATTENTION: The concrete risk due to the machine depends on the conditions in which it is used. Therefore, it is up to the end-user and under his direct responsibility to make a correct evaluation of the same risk and to adopt specific precautions (for instance, adopting a I.P.D. -Individual Protection Device)

Acoustic Noise Level (LWA) - Measure Unit dB(A): it stands for acoustic noise released in a certain delay of time. This is not submitted to the distance of measurement.

Acoustic Pressure (Lp) - Measure Unit dB(A): it measures the pressure originated by sound waves emission. Its value changes in proportion to the distance of measurement.

The here below table shows examples of acoustic pressure (Lp) at different distances from a machine with Acoustic Noise Level (LWA) of 95 dB(A)

Lp a 1 meter = 95 dB(A) - 8 dB(A) = 87 dB(A)

Lp a 7 meters = 95 dB(A) - 25 dB(A) = 70 dB(A)

Lp a 4 meters = 95 dB(A) - 20 dB(A) = 75 dB(A)

Lp a 10 meters = 95 dB(A) - 28 dB(A) = 67 dB(A)

PLEASE NOTE: the symbol  when with acoustic noise values, indicates that the device respects noise emission limits according to 2000/14/CE directive.

SYMBOLS IN THIS MANUAL

- The symbols used in this manual are designed to call your attention to important aspects of the operation of the machine as well as potential hazards and dangers for persons and things.

IMPORTANT ADVICE

- Advice to the User about the safety:

☞ N.B.: The information contained in the manual can be changed without notice. Potential damages caused in relation to the use of these instructions will not be considered because these are only indicative. Remember that the non observance of the indications reported by us might cause damage to persons or things. It is understood, that local dispositions and/or laws must be respected.

WARNING



Situations of danger - no harm to persons or things

Do not use without protective devices provided

Removing or disabling protective devices on the machine is prohibited.

Do not use the machine if it is not in good technical condition

The machine must be in good working order before being used. Defects, especially those which regard the safety of the machine, must be repaired before using the machine.

SAFETY PRECAUTIONS



DANGEROUS

This heading warns of an immediate danger for persons as well for things. Not following the advice can result in serious injury or death.



WARNING

This heading warns of situations which could result in injury for persons or damage to things.



CAUTION

To this advice can appear a danger for persons as well as for things, for which can appear situations bringing material damage to things.



IMPORTANT



NOTE



ATTENTION

These headings refer to information which will assist you in the correct use of the machine and/or accessories.

SYMBOLS



STOP - Read absolutely and be duly attentive



Read and pay due attention



GENERAL ADVICE - If the advice is not respected damage can happen to persons or things.



HIGH VOLTAGE - Attention High Voltage. There can be parts in voltage, dangerous to touch. The non observance of the advice implies life danger.



FIRE - Danger of flame or fire. If the advice is not respected fires can happen.



HEAT - Hot surfaces. If the advice is not respected burns or damage to things can be caused.



EXPLOSION - Explosive material or danger of explosion. in general. If the advice is not respected there can be explosions.



WATER - Danger of shortcircuit. If the advice is not respected fires or damage to persons can be caused.



SMOKING - The cigarette can cause fire or explosion. If the advice is not respected fires or explosions can be caused.



ACIDS - Danger of corrosion. If the advice is not respected the acids can cause corrosions with damage to persons or things.



WRENCH - Use of the tools. If the advice is not respected damage can be caused to things and even to persons.



PRESSION - Danger of burns caused by the expulsion of hot liquids under pressure.



ACCES FORBIDDEN to non authorizad people.

PROHIBITIONS No harm for persons

Use only with safety clothing -



It is compulsory to use the personal protection means given in equipment.

Use only with safety clothing -



It is compulsory to use the personal protection means given in equipment.

Use only with safety protections -



It is a must to use protection means suitable for the different welding works.

Use with only safety material -



It is prohibited to use water to quench fires on the electric machines.

Use only with non inserted voltage -



It is prohibited to make interventions before having disinserted the voltage.

No smoking -



It is prohibited to smoke while filling the tank with fuel.

No welding -



It is forbidden to weld in rooms containing explosive gases.

ADVICE No harm for persons and things

Use only with safety tools, adapted to the specific use -

It is advisable to use tools adapted to the various maintenance works.

Use only with safety protections, specifically suitable



It is advisable to use protections suitable for the different welding works.

Use only with safety protections -



It is advisable to use protections suitable for the different daily checking works.

Use only with safety protections -



It is advisable to use all protections while shifting the machine.

Use only with safety protections -



It is advisable to use protections suitable for the different daily checking works.and/or of maintenance.

 The installation and the general advice concerning the operations, are finalized to the correct use of the machine, in the place where it is used as generator group and/or welder.

ENGINE	Stop engine when fueling	CHECKING BOARD	Do not touch electric devices if you are barefoot or with wet clothes.
	Do not smoke, avoid flames, sparks or electric tools when fueling.		Always keep off leaning surfaces during work operations.
	Unscrew the cap slowly to let out the fuel vapours.		Static electricity can damage the parts on the circuit.
	Slowly unscrew the cooling liquid tap if the liquid must be topped up.		An electric shock can kill
	The vapor and the heated cooling liquid under pressure can burn face, eyes, skin.		
	Do not fill tank completely.		
	Wipe up spilled fuel before starting engine.		
	Shut off fuel of tank when moving machine (where it is assembled).		
	Avoid spilling fuel on hot engine.		
Sparks may cause the explosion of battery vapours			



FIRST AID. In case the operator should be sprayed by accident, from corrosive liquids a/o hot toxic gas or whatever event which may cause serious injuries or death, predispose the first aid in accordance with the ruling labour accident standards or of local instructions.

Skin contact	Wash with water and soap
Eyes contact	Irrigate with plenty of water, if the irritation persists contact a specialist
Ingestion	Do not induce vomit as to avoid the intake of vomit into the lungs, send for a doctor
Suction of liquids from lungs	If you suppose that vomit has entered the lungs (as in case of spontaneous vomit) take the subject to the hospital with the utmost urgency
Inhalation	In case of exposure to high concentration of vapours take immediately to a non polluted zone the person involved



FIRE PREVENTION. In case the working zone, for whatsoever cause goes on fire with flames liable to cause severe wounds or death, follow the first aid as described by the ruling norms or local ones.

EXTINCTION MEANS	
Appropriated	Carbonate anhydride (or carbon dioxide) powder, foam, nebulized water
Not to be used	Avoid the use of water jets
Other indications	Cover eventual shedding not on fire with foam or sand, use water jets to cool off the surfaces close to the fire
Particular protection	Wear an autorespiratory mask when heavy smoke is present
Useful warnings	Avoid, by appropriate means to have oil sprays over metallic hot surfaces or over electric contacts (switches, plugs, etc.). In case of oil sprinkling from pressure circuits, keep in mind that the inflammability point is very low.

WARNING					CAUTION		DANGER

 WARNING	THE MACHINE <u>MUST NOT BE USED</u> IN AREAS WITH EXPLOSIVE ATMOSPHERE
--------------------	---



INSTALLATION AND ADVICE BEFORE USE

The operator of the welder is responsible for the security of the people who work with the welder and for those in the vicinity.

The security measures must satisfy the rules and regulations for engine driven welders.

The information given below is in addition to the local security norms.

Estimate possible electromagnetic problems in the work area taking into account the following indications.

1. Telephonic wirings and/or of communication, check wirings and so on, in the immediate vicinity.
2. Radio and television receptors and transmitters.
3. Computer and other checking devices.
4. Critical devices for safety and/or for industrial checks.
5. People who, for instance, use pace-maker, hearing-aid for deaf or something and else.
6. Devices used for rating and measuring.
7. The immunity of other devices in the operation area of the welder. Make sure that other used devices are compatible. If it is the case, provide other additional measures of protection.
8. The daily duration of the welding time.



Make sure that the area is safe before starting any welding operation.

- Do not touch any bare wires, leads or contacts as they may be live and there is danger of electric shock which can cause death or serious burns. The electrode and welding cables, etc. are live when the unit is operating.
- Do not touch any electrical parts or the electrode while standing in water or with wet hands, feet or clothes.
- Insulate yourself from the work surface while welding. Use carpets or other insulating materials to avoid physical contact with the work surface and the floor.
- Always wear dry, insulating gloves, without holes, and body protection.
- Do not wind cables around the body.
- Use ear protections if the noise level is high.
- Keep flammable material away from the welding area.
- Do not weld on containers which contain flammable material.
- Do not weld near refuelling areas.
- Do not weld on easily flammable surfaces.
- Do not use the welder to defrost (thaw) pipes.
- Remove the electrode from the electrode holder, when not welding.
- Avoid inhaling fumes by providing a ventilation system or, if not possible, use an approved air breather.
- Do not work in closed areas where there is no fresh air flow.
- Protect face and eyes (protective mask with suitable dark lens and side screens), ears and body (non-flammable protective clothers).



INSTALLATION AND ADVICE BEFORE USE

GASOLINE ENGINES

- ☞ Use in open space, air swept or vent exhaust gases, which contain the deadly carbone oxyde, far from the work area.

DIESEL ENGINES

- ☞ Use in open space, air swept or vent exhaust gases far from the work area.

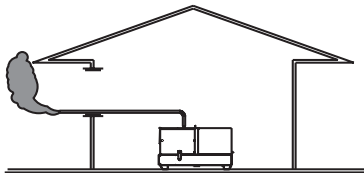
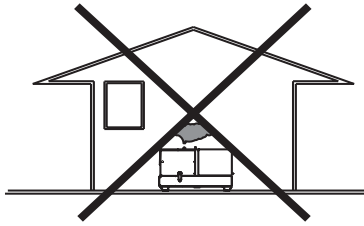

POSITION

Place the machine on a level surface at a distance of at least 1,5 m from buildings or other plants.

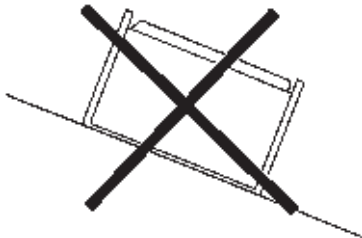

Maximum leaning of the machine (in case of dislevel)

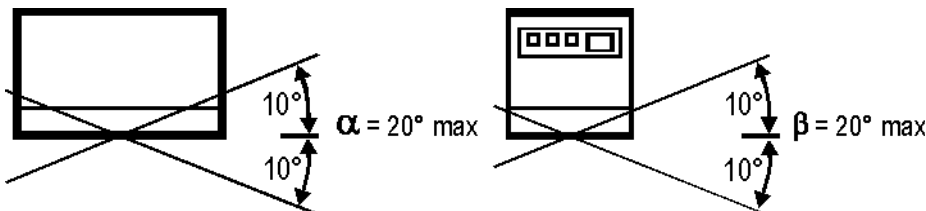

Check that the air gets changed completely and the hot air sent out does not come back inside the set so as to cause a dangerous increase of the temperature.

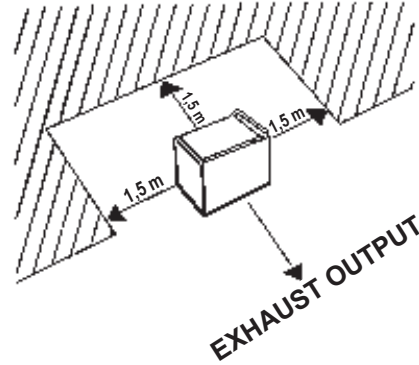

- ☞ Make sure that the machine does not move during the work: **block** it possibly with tools and/or devices made to this purpose.

MOVES OF THE MACHINE

- ☞ At any move check that the engine is **off**, that there are no connections with cables which impede the moves.

PLACE OF THE MACHINE



ATTENTION



For a safer use from the operator **DO NOT** fit the machine in locations with high risk of flood.

Please do not use the machine in weather conditions which are beyond IP protection shown both in the data plate and on page named "technical data" in this same manual.

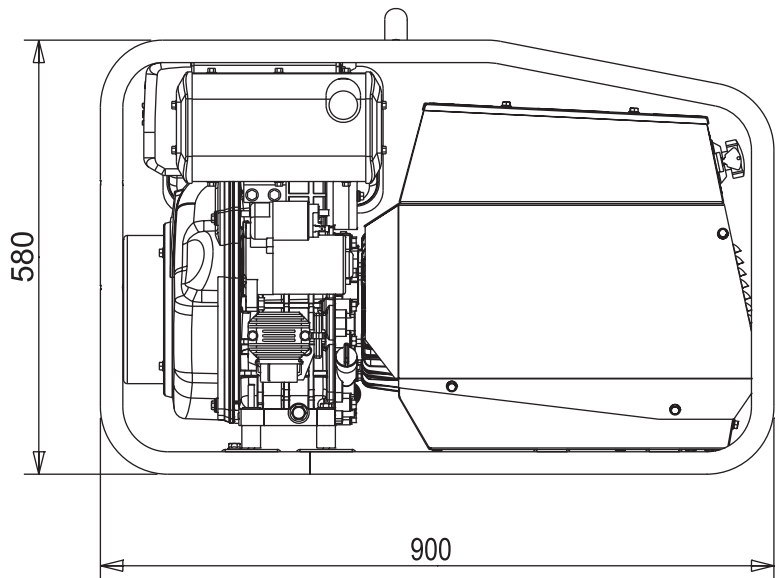
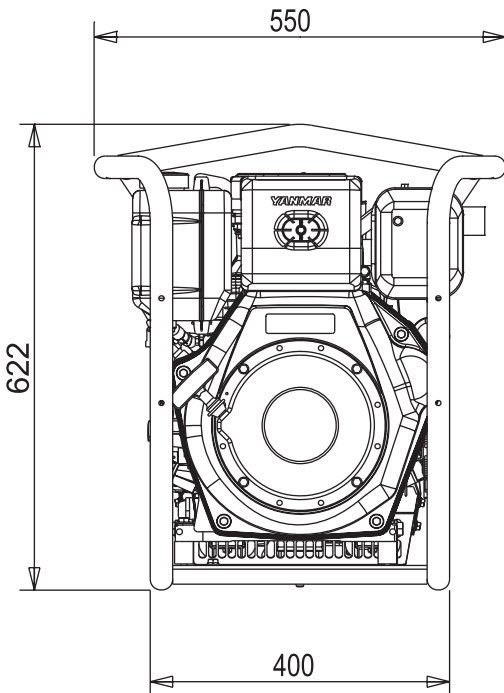
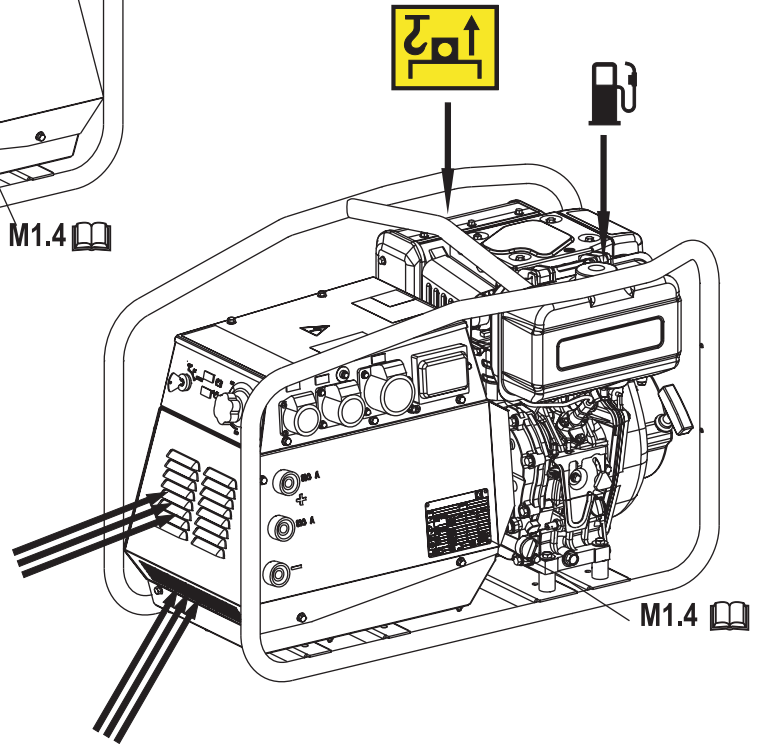
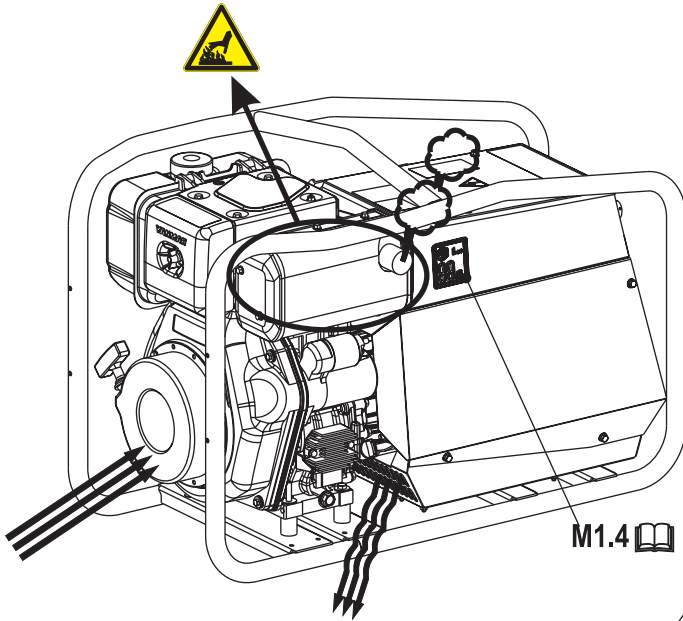



NOTE

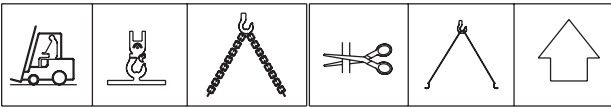

Be sure that the lifting devices are: correctly mounted, adequate for the weight of the machine with its packaging, and conforms to local rules and regulations. When receiving the goods make sure that the product has not suffered damage during the transport, that there has not been rough handling or taking away of parts contained inside the packing or in the set. In case you find damages, rough handling or absence of parts (envelopes, manuals, etc.), we advise you to inform immediately our Technical Service.

For eliminating the packing materials, the User must keep to the norms in force in his country.

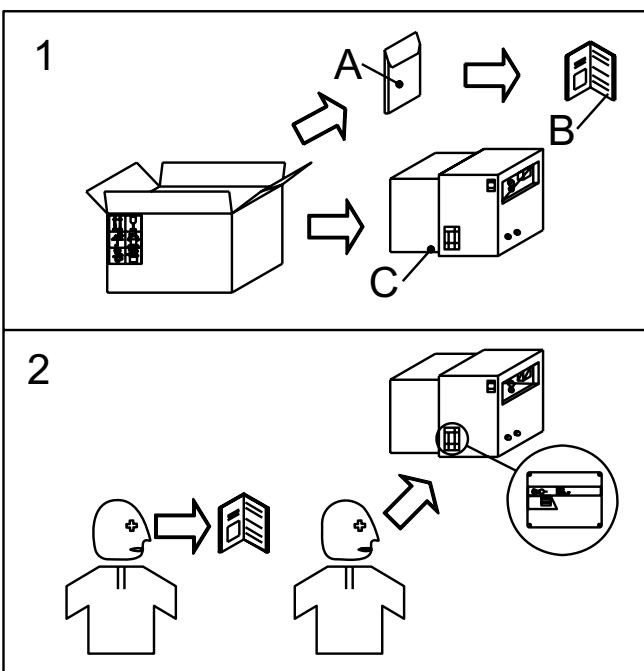
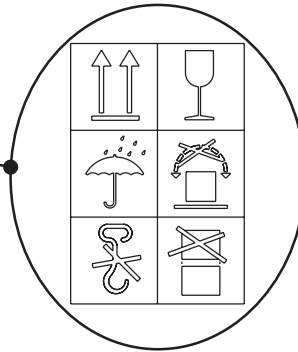
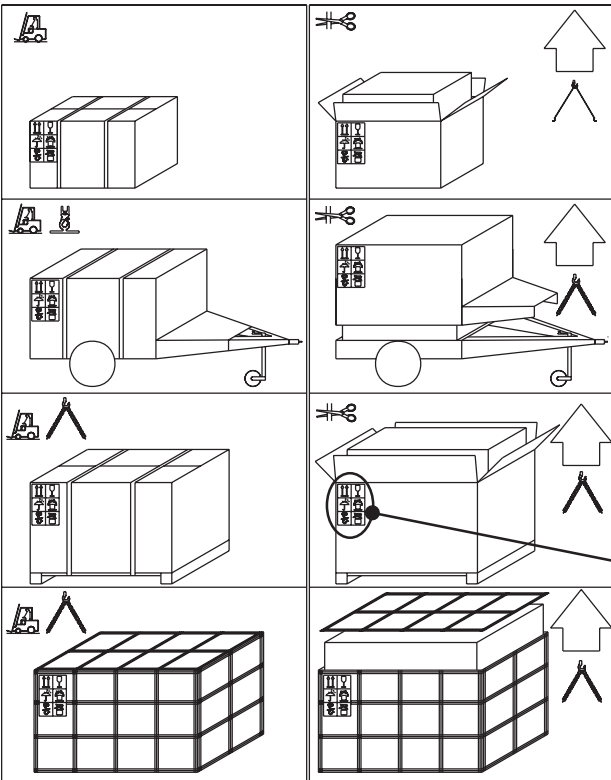

- 1) Take the machine (C) out of the shipment packing. Take out of the envelope (A) the user's manual (B).
- 2) Read: the user's manual (B), the plates fixed on the machine, the data plate.





NOTE

Transportation must always take place with the engine off, electrical cables and starting battery disconnected and fuel tank empty.

Be sure that the lifting devices are: correctly mounted, adequate for the weight of the machine with its packaging, and conform to local rules and regulations.

Only authorized persons involved in the transport of the machine should be in the area of movement.

DO NOT LOAD OTHER PARTS WHICH CAN MODIFY WEIGHT AND BARICENTER POSITION.

IT IS STRICTLY FORBIDDEN TO DRAG THE MACHINE MANUALLY OR TOW IT BY ANY VEHICLE (model with no CTM accessory).

If you did not keep to the instructions, you could damage the structure of the machine.

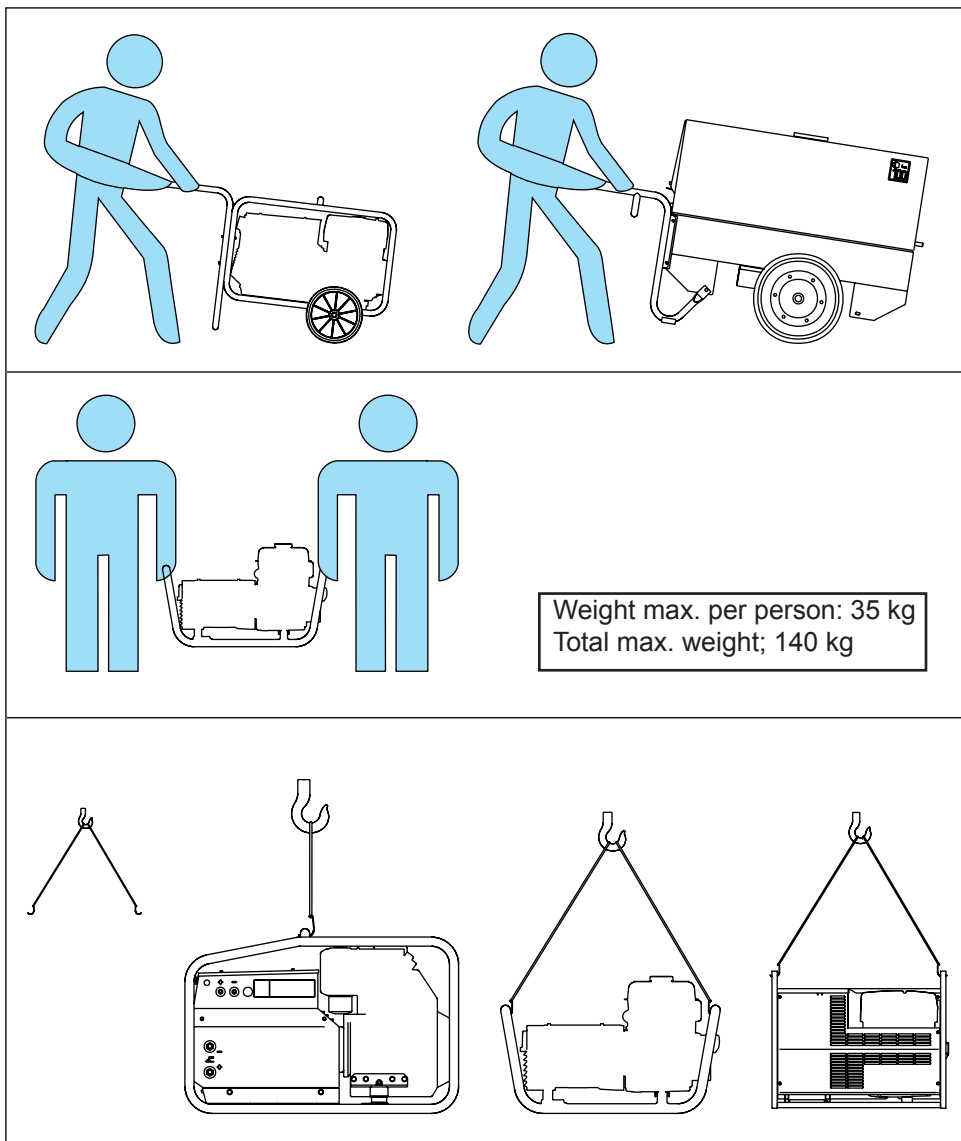



ATTENTION

The CTM accessory cannot be removed from the machine and used separately (actioned manually or following vehicles) for the transport of loads or anyway for used different from the machine movements.

Note: Lift the machine and assemble the parts as shown in the drawing

CTM 6/2

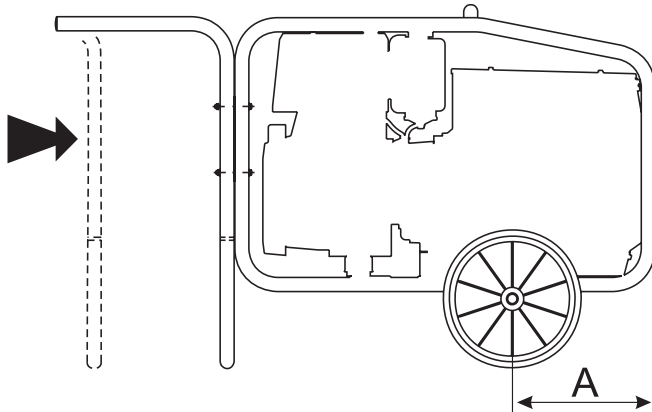

CTM 6/6UK

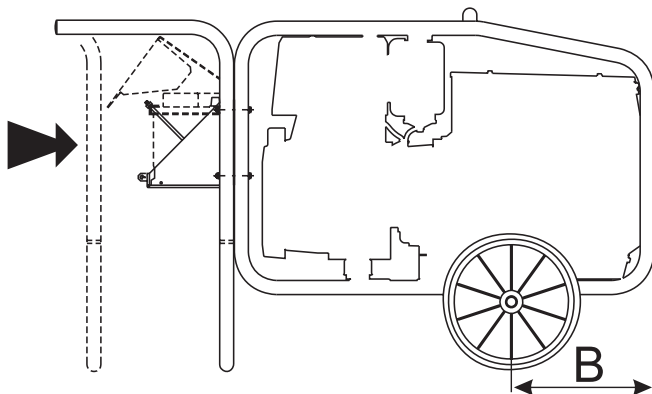

CTM 200

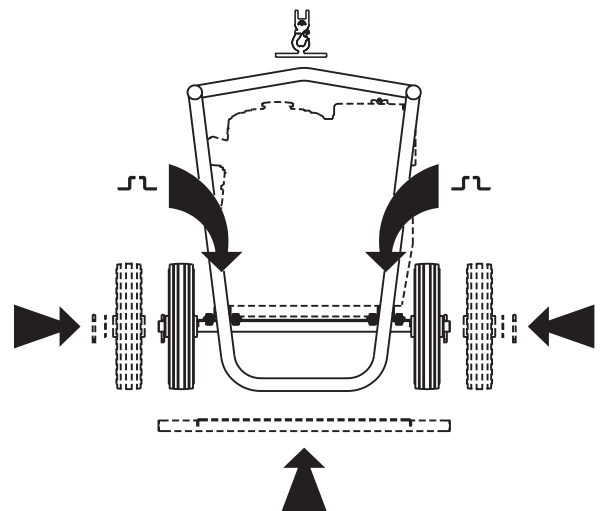
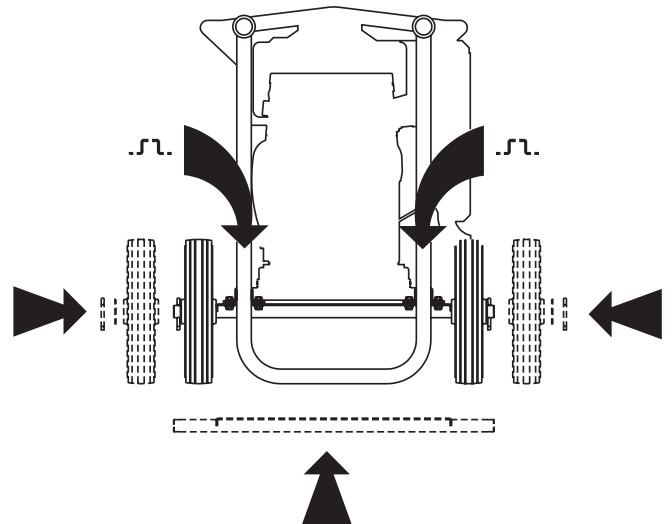
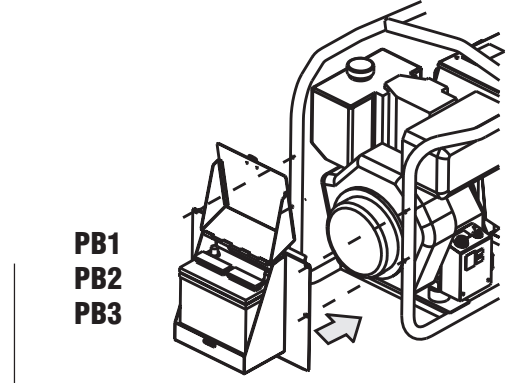
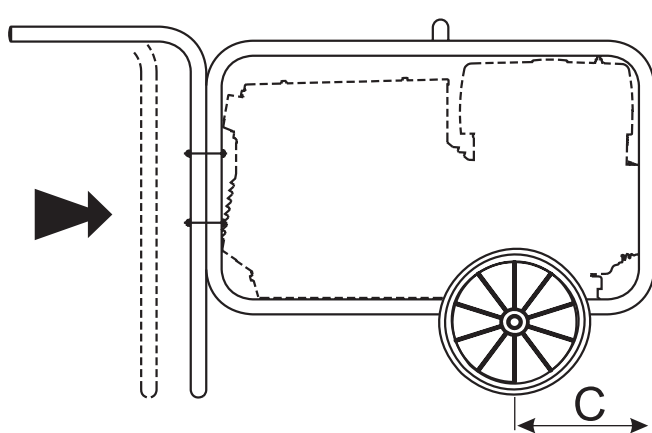

GE 7000 BS/GS	CTM 200	C	145 mm
GE 6000 DS/GS	CTM 6/2	A	310 mm
GE 6000 DES/GS	CTM 6/6UK	B	400 mm
GE 7500 BS/GS	CTM 200	C	205 mm
GE 6500 DS/GS	CTM 6/2	A	400 mm
GE 6500 DES/GS	CTM 6/6UK	B	400 mm





BATTERY WITHOUT MAINTENANCE



Connect the cable + (positive) to the pole + (positive) of the battery (after having taken away the protection), by properly tightening the clamp.

Check the state of the battery from the colour of the warning light which is in the upper part.

- Green colour: battery OK
- Black colour: battery to be recharged
- White colour: battery to be replaced

DO NOT OPEN THE BATTERY.



LUBRICANT

RECOMMENDED OIL

MOSA recommends selecting **AGIP** engine oil. Refer to the label on the motor for the recommended products.

 PRODOTTI RACCOMANDATI RECOMMENDED PRODUCTS	
AGIP SIGMA TURBO PLUS 15W/40 API CG4 - ACEA E3	OLIO MOTORE DIESEL DIESEL ENGINE OIL
AGIP SUPERMOTOROIL 20W/50 API CC-SF	OLIO MOTORE BENZINA GASOLINE ENGINE OIL
AGIP ANTIFREEZE EXTRA INIBITE ETHYLENE GLYCOL (50% + 50% + H ₂ O)	CIRCUITO DI RAFFREDDAMENTO COOLING CIRCUIT (CUNA NC 956-16 ED 97)

Please refer to the motor operating manual for the recommended viscosity.

REFUELLING AND CONTROL:

Carry out refuelling and controls with motor at level position.

1. Remove the oil-fill tap (24)
2. Pour oil and replace the tap
3. Check the oil level using the dipstick (23); the oil level must be comprised between the minimum and maximum indicators.



ATTENTION

It is dangerous to fill the motor with too much oil, as its combustion can provoke a sudden increase in rotation speed.



DRY AIR FILTER

Check that the dry air filter is correctly installed and that there are no leaks around the filter which could lead to infiltrations of non-filtered air to the inside of the motor.



OIL BATH AIR FILTER

Fill the air filter using the same engine oil up to the level indicated on the filter.



FUEL



ATTENTION



Do not smoke or use open flames during refuelling operations, in order to avoid explosions or fire hazards.

Fuel fumes are highly toxic; carry out operations outdoors only, or in a well-ventilated environment.



Avoid accidentally spilling fuel. Clean any eventual leaks before starting up motor.

Refill the tank with good quality diesel fuel, such as automobile type diesel fuel, for example.

For further details on the type of diesel fuel to use, see the motor operating manual supplied.

Do not fill the tank completely; leave a space of approx. 10 mm between the fuel level and the wall of the tank to allow for expansion.

In rigid environmental temperature conditions, use special winterized diesel fuels or specific additives in order to avoid the formation of paraffin.



GROUNDING CONNECTION

The grounding connection to an earthed installation **is obligatory** for all models equipped with a differential switch (circuit breaker). In these groups the generator star point is generally connected to the machine's earthing; by employing the TN or TT distribution system, the differential switch guarantees protection against indirect contacts.

In the case of powering complex installations requiring or employing additional electrical protection devices, the coordination between the protection devices must be verified.

For the grounding connection, use the terminal (12); comply to local and/or current regulations in force for electrical installations and safety.





check daily



NOTE

Do not alter the primary conditions of regulation and do not touch the sealed parts.

MANUAL RECOIL VERSION

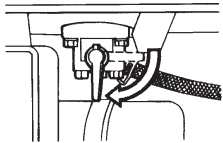
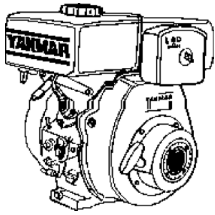

1) Open the fuel cock

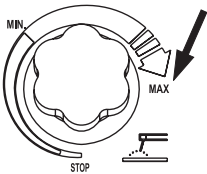

2) turn the welding current control knob (16T) to the maximum (fully counter-clockwise)



3) hold the starting handle properly



4) pull the starting handle slowly...

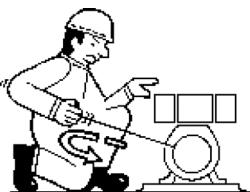

5) ... until you feel resistance

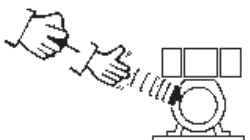

6) then return it slowly

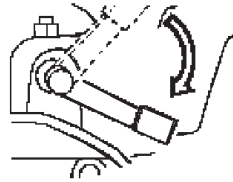

7) push the decompression lever down and release



8) hold the starting handle firmly



9) pull the rope hard and fast. Pull it all the way out. Use two hands if necessary.

ELECTRIC STARTING VERSION

Effect the operations 1), 2) and 7) as reported in the para **Recoil starter**.

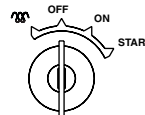

Turn the starting key (Q1) completely clockwise, until the motor starts.

Let the engine run for some minutes before drawing the load.

In case of unsuccessful start-up, do not insist for longer than 5 seconds. Wait 10 seconds before attempting another start-up.

Emergency recoil start

Turn the starting key (Q1) in "ON" position and repeat the process of recoil starting.



ATTENTION

If battery is not connected, disconnect voltage regulator to prevent damage.



CAUTION

RUNNING IN

During the first 50 hours do not use the unit at more than 60% of full load. Check the oil level regularly.



- ☞ Before stopping the engine **it is compulsory** to stop the load:
- shut off any loads which are connected to the unit auxiliary outputs;
 - disconnect the electric protection device (D);
 - stop welding

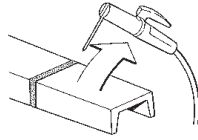

stopping the engine:

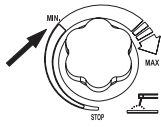

- Reduce the speed of the engine turning the knob (16/T) on the MIN position (counter clockwise) and let it idle for about 3 minutes

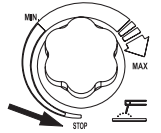

- Turn off the engine turning the knob (16/T) on the position STOP (completely counter clockwise).

Electric starting version

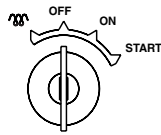

- Remove the key (Q1) turning it counter clockwise, OFF position, then take it out.

- ☞ **NB.:** for safety reason the key must be kept by qualified personel.

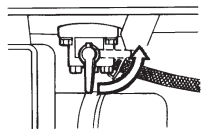

Shut the fuel cock.

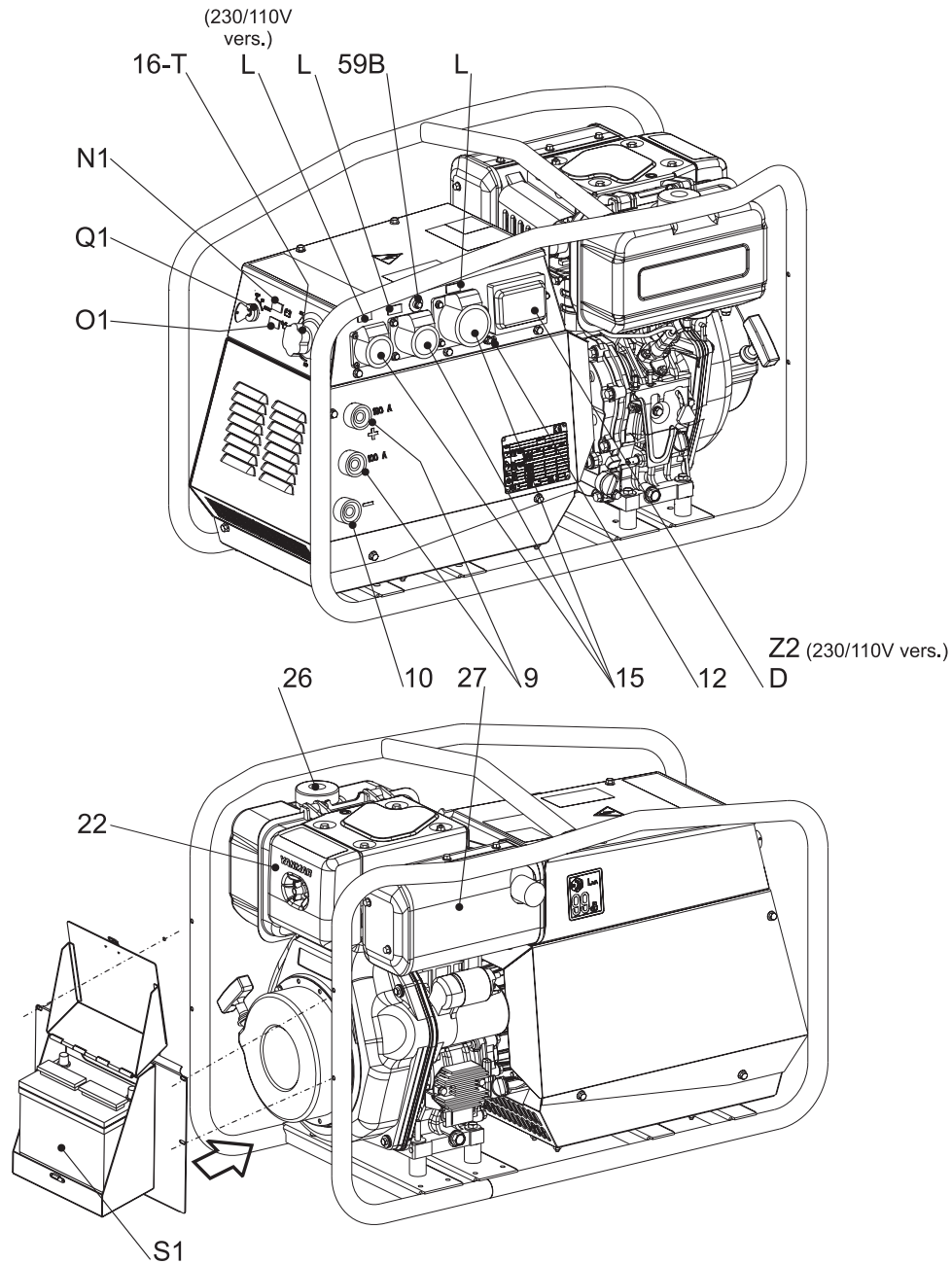

Pos.	Descrizione	Description	Description	Descripción
9	Presa di saldatura (+)	Welding socket (+)	Prise de soudage (+)	Toma de soldadura (+)
10	Presa di saldatura (-)	Welding socket (-)	Prise de soudage (-)	Toma de soldadura (-)
12	Presa di messa a terra	Earth terminal	Prise de mise à terre	Toma de puesta a tierra
15	Presa di corrente in c.a.	A.C. socket	Prises de courant en c.a.	Toma de corriente en c.a
16	Comando acceler./puls. marcia	Accelerator lever	Commande accélér./bouton marche	Mando de acel./pulsador marcha
22	Filtro aria motore	Engine air filter	Filtre air moteur	Filtro aire motor
26	Tappo serbatoio	Fuel tank cap	Bouchon - réservoir	Tapón depósito
27	Silenziatore di scarico	Muffler	Silencieux d'échappement	Silenciador de descarga
59B	Protezione termica corrente aux	Aux current thermal switch	Protection thermique courant aux.	Protección térmica corr. aux
D	Interruttore differenziale (30mA)	G.F.I.	Interrupteur différentiel	Interruptor diferencial (30 mA)
L	Spia luminosa corrente alternata	A.C. output indicator	Voyants tension alternative	Indicadores luminosos c. alter.
N1	Spia carica batteria	Battery charge warning light	Voyant charge batterie	Piloto carga batería
O1	Spia lumin. press. olio/oil alert	Oil press.warning light/oil alert	Voyant lumin. press.huile / oil alert	Indic.lum.pres. aceite/oil alert
Q1	Chiave di avviamento	Starter key	Clé de démarrage	Llave de arranque
S1	Batteria	Battery	Batterie	Batería
T	Regolatore corrente di saldatura	Welding current regulator	Régulateur courant soudage	Regulador corr. de soldadura
Z2	Interruttore magnetotermico	Thermal-magnetic circ.breaker	Interrupteur magnétothermique	Interruptor magnetotérmico

S This symbol (Norm EN 60974-1 security standards for arc welders) signifies that the welders can be used in areas with increased risk of electrical shock.

CONNECT WELDING CABLES

For direct current electrode positive, connect work cable to negative (-) terminal and electrode holder to positive (+) terminal. For direct current electrode negative, reverse cable connections. Turn them clockwise to lock them in position. Loose plugs will result in poor welding and damage to both plug and socket.

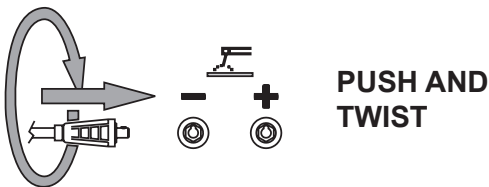

WELDING CURRENT REGULATION

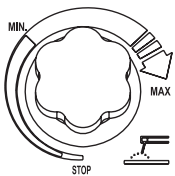

Once the welding current range has been chosen by attaching the electrode holder lead to the corresponding socket, the welding current is adjusted by turning the knob on the front panel. The knob regulates the rpm of the engine.



ATTENTION

To reduce the risk of electromagnetic interference, keep the welding cable length short and keep them on or near the ground. Ensure that the machine is grounded. If possible, welding operations should not be done near sensitive electronic devices.



WARNING

It is absolutely forbidden to connect the unit to the public mains and/or another electrical power source .

Areas for which access by non-authorized personnel is **forbidden** are:
 - the control panel (at the front) - the endothermic motor discharge.

ENGINE SPEED FOR CORRECT VOLTAGE AND FREQUENCY

Turn the welding current regulating knob fully clockwise to put the engine at its maximum rpm. If the engine is not at full rpm the voltage and the frequency of the auxiliary power will not be correct. At no load the voltage can be 10% above nominal and at full load the voltage can be 10% below nominal.

PLUGS AND CABLES

Before connecting a load to the socket check that the cables are in good condition and that the plug is wired correctly.

POWER ON LIGHT

The light (L), located above each socket, lights up when there is power available from the socket.

☞ If the warning light does not light, check that the engine is at maximum rpm, that the GFI (ground fault interrupter) is inserted and that the circuit breaker is functioning.

When drawing power from more than one socket at the same time, the power available is that indicated for each socket but the total cannot exceed the maximum shown on the rating plate.

GROUND FAULT INTERRUPTOR SWITCH

The high-sensitivity ground fault interruptor switch [G.F.I.] (30mA) (D), guarantees protection against indirect contacts due to faulty ground currents .

When the G.F.I. switch picks up a faulty ground current that is higher than 30mA, it intervenes by immediately cutting off tension to the AC sockets.

In case of intervention by this protection feature, reset the G.F.I. switch, bringing the lever to the ON position.

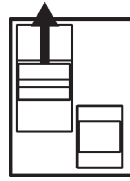

In case of another intervention, verify that no faulty tools are connected, or replace the G.F.I. switch with another of matching specifications and/or contact the Service Department.

☞ Notes: verify the operation of the G.F.I. switch at least once a month by pressing the TEST button. The generator must be running and the differential lever in the ON position.

CIRCUIT BREAKERS FOR SOCKETS

If you overload the socket the circuit breaker will automatically switch off the power.

To reset the circuit breaker, disconnect the load, wait a few seconds for the circuit breaker to cool down and then push the button. The button should stay depressed. If the circuit breaker button does not stay in, let it cool down and try again. If it still will not stay in call the service.

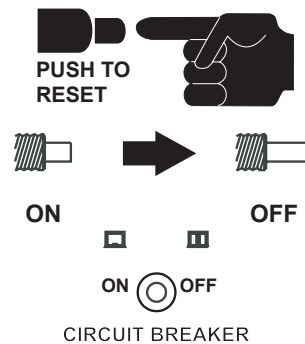

Before reconnecting the load check that the power required is within the rating of the socket. A load which is too large for the socket will cause the circuit breaker to intervene. If, after reconnecting the load, the circuit breaker opens again, check the connections, wires, etc. of the load to find the fault.

UNIT FITTED WITH THERMAL MAGNETIC BREAKER

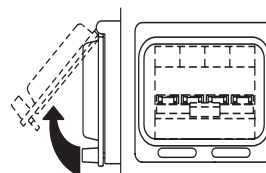

Turn on the thermal magnetic breaker (Z2) by pushing it to the ON position.

The thermal-magnetic breaker is a safety device which protects the circuit in the event of a malfunction. In this case the switch disconnects the three and single-phase circuit when in any part of the electric connections a short circuit or a current absorption occurs above the data specified on the label of the unit.



The warning lamps brighten by turning the engine starting key (Q1) and they switch off after some seconds.

The engine protection, in case of low oil pressure, is shown by the warning light (O1) without the engine stopping.



The same as for as the battery charger warning (O1) light in concerned, the anomaly is shown without the engine stopping.



If the trouble should persist, please turn to your Assistance Centre.

Once the cause of the problem is removed, to assure the protection it is enough to put the starting key (Q1) to zero ("OFF" position) and start the engine again.

PROBLEM	POSSIBLE CAUSE	WHAT TO DO
No welding current but auxiliary output is OK	1) Defective diode bridge 2) Problem with welding current control (PCB)	1) Check the diodes of the bridge 2) Is the remote control switch in the internal position? 3) Check the diodes and SCR's of the bridge. 4) Check the transformer which supplies power to the welding control PCB. If it is OK replace the PCB
Weld poorly	1) Defective diode bridge 2) Problem with welding current control (PCB)	1) Check the open circuit welding voltage. If it is OK the diode bridge is OK. If it is 1/3 or 2/3 of the nominal value check the diodes or the SCR's. 2) If the diode bridge is OK replace the PCB.
Intermittently welds poorly	1) Bad connections to welding current PCB 2) Problem with welding current control PCB	1) Check that the pins of the green connectors are clean and making good contact. Check that shunt connections are tight. 2) Replace the welding current control PCB
No welding output and no auxiliary power output	1) Short circuit in wiring 2) Defective condenser 3) Defective stator 4) Short circuited diode bridge	1) Check the wiring inside the welder for a short circuit between cables or to ground. 2) If the wiring is OK, short circuit the condenser to be sure that it is discharged, disconnect all wires from condenser and, using an ohmmeter, check that the condenser is not short circuited. 3) If the condenser box is OK, disconnect all leads from the stator except for those going to the condenser box and check the output from the alternator. If there is no output from the welding winding and the auxiliary winding, replace the stator. 4) If there is output from all windings reconnect the diode bridge and check if there is welding current. If not the diode bridge is defective. If there is welding current connect the auxiliary power leads one at a time until there is no output; at this point, the short circuit is in that line.

[.] only for models with electronic control of welding current.



WARNING



**MOVING
PARTS
can injure**

- Have **qualified** personnel do maintenance and troubleshooting work.
- Stop the engine before doing any work inside the machine. If for any reason the machine must be operated while working inside, **pay attention** moving parts, hot parts (exhaust manifold and muffler, etc.) electrical parts which may be unprotected when the machine is open.
 - Remove guards only when necessary to perform maintenance, and replace them when the maintenance requiring their removal is complete.
 - Use suitable tools and clothes.
 - Do not modify the components if not authorized.
- See pag. M1.1 -



**HOT surface
can
hurt you**

NOTE

By maintenance at care of the utilizer we intend all the operatios concerning the verification of mechanical parts, electrical parts and of the fluids subject to use or consumption during the normal operation of the machine.

For what concerns the fluids we must consider as maintenance even the periodical change and or the refills eventually necessary.

Maintenance operations also include machine cleaning operations when carried out on a periodic basis outside of the normal work cycle.

The repairs **cannot be considered** among the maintenance activities, i.e. the replacement of parts subject to occasional damages and the replacement of electric and mechanic components consumed in normal use, by the Assistance Authorized Center as well as by MOSA.

The replacement of tires (for machines equipped with trolleys) must be considered as repair since it is not delivered as standard equipment any lifting system.

The periodic maintenance should be performed according to the schedule shown in the engine manual. An optional hour counter (M) is available to simplify the determination of the working hours.



IMPORTANT



In the maintenance operations avoid that polluting substances, liquids, exhausted oils, etc. bring damage to people or things or can cause negative effects to surroundings, health or safety respecting completely the laws and/or dispositions in force in the place.

ENGINE and ALTERNATOR

PLEASE REFER TO THE SPECIFIC MANUALS PROVIDED.

Every engine and alternator manufacturer has

maintenance intervals and specific checks for each model: it is necessary to consult the specific engine or alternator USER AND MAINTENANCE manual.

VENTILATION

Make certain there are no obstructions (rags, leaves or other) in the air inlet and outlet openings on the machine, alternator and motor.

ELECTRICAL PANELS

Check condition of cables and connections daily. Clean periodically using a vacuum cleaner, **DO NOT USE COMPRESSED AIR.**

DECALS AND LABELS

*All warning and decals should be checked once a year and **replaced** if missing or unreadable.*

STRENUOUS OPERATING CONDITIONS

Under extreme operating conditions (frequent stops and starts, dusty environment, cold weather, extended periods of no load operation, fuel with over 0.5% sulphur content) do maintenance more frequently.

BATTERY WITHOUT MAINTENANCE DO NOT OPEN THE BATTERY

The battery is charged automatically from the battery charger circuit supplied with the engine.

Check the state of the battery from the colour of the warning light which is in the upper part.

- Green colour: battery OK
- Black colour: battery to be recharged
- White colour: battery to be replaced



NOTE

THE ENGINE PROTECTION NOT WORK WHEN THE OIL IS OF LOW QUALITY BECAUSE NOT CHARGED REGULARLY AT INTERVALS AS PRESCRIBED IN THE OWNER'S ENGINE MANUAL.

In case the machine should not be used for more than 30 days, make sure that the room in which it is stored presents a suitable shelter from heat sources, weather changes or anything which can cause rust, corrosion or damages to the machine.

☞ Have **qualified** personnel prepare the machine for storage.

GASOLINE ENGINE

Start the engine: It will run until it stops due to the lack of fuel.

Drain the oil from the engine sump and fill it with new oil (see page M25).

Pour about 10 cc of oil into the spark plug hole and screw the spark plug, after having rotated the crankshaft several times.

Rotate the crankshaft slowly until you feel a certain compression, then leave it.

In case the battery, for the electric start, is assembled, disconnect it.

Clean the covers and all the other parts of the machine carefully.

Protect the machine with a plastic hood and store it in a dry place.

DIESEL ENGINE

For short periods of time it is advisable, about every 10 days, to make the machine work with load for 15-30 minutes, for a correct distribution of the lubricant, to recharge the battery and to prevent any possible blocking of the injection system.

For long periods of inactivity, turn to the after sales service of the engine manufacturer.

Clean the covers and all the other parts of the machine carefully.

Protect the machine with a plastic hood and store it in a dry place.

In case of necessity for first aid and of fire prevention, see page. M2.5.



IMPORTANT



In the storage operations avoid that polluting substances, liquids, exhausted oils, etc. bring damage to people or things or can cause negative effects to surroundings, health or safety respecting completely the laws and/or dispositions in force in the place.

☞ Have **qualified** personnel disassemble the machine and dispose of the parts, including the oil, fuel, etc., in a correct manner when it is to be taken out of service.

In case of necessity for first aid and fire prevention, see page M2.5.

As cust off we intend all operations to be made, at utilizer's care, at the end of the use of the machine. This comprises the dismantling of the machine, the subdivision of the several components for a further reutilization or for getting rid of them, the eventual packing and transportation of the eliminated parts up to their delivery to the store, or to the bureau entrusted to the cust off or to the storage office, etc.

The several operations concerning the cust off, involve the manipulation of fluids potentially dangerous such as: lubricating oil and battery electrolyte.

The dismantling of metallic parts liable to cause injuries or wounds, must be made wearing heavy gloves and using suitable tools.

The getting rid of the various components of the machine must be made accordingly to rules in force of law a/o local rules.

Particular attention must be paid when getting rid of:

lubricating oils, battery electrolyte, and inflammable liquids such as fuel, cooling liquid.

The machine user is responsible for the observance of the norms concerning the environment conditions with regard to the elimination of the machine being cust off and of all its components.

In case the machine should be cust off without any previous disassembly it is however compulsory to remove:

- tank fuel
- engine lubricating oil
- cooling liquid from the engine
- battery

NOTE: BCS is involved with custing off the machine **only** for the second hand ones, when not reparable. This, of course, after authorization.

IMPORTANT

In the cust-off operations avoid that polluting substances, liquids, exhausted oils, etc. bring damage to people or things or can cause negative effects to surroundings, health or safety respecting completely the laws and/or dispositions in force in the place.

The information here below are to be intended only as indicative since the above norm is much larger. For further details please see the specific norms and/or the manufacturers of the product to be used in the welding process.

RUTILE ELECTRODES: E 6013

Easily removable fluid slag, suitable for welding in all position. Rutile electrodes weld in d.c. with both polarities (electrode holder at + or -) and in a.c.. Suitable for soft steels R-38/45 kg/mm². Also for soft steels of lower quality.

BASIC ELECTRODES: E 7015

Basic electrodes weld only in d.c. with inverse polarity (+ on the electrode holder) ; there are also types for a.c. Suitable for impure carbon steels. Weld in all position.

HIGH YIELD BASIC ELECTRODES: E 7018

The iron contained in the coating increases the quality of metal added. Good mechanical properties. Weld in all position. Electrode holder at + (inverse polarity). Weld deposit of nice aspect, also vertical. Workable; high yield. Suitable for steels with high contents of sulphur (impurities).

CELLULOSIC ELECTRODES: E 6010

Cellulosic electrodes weld only in d.c. with polarity + electrode holder - ground clamp. Special for steels run on pipes with R max 55 kg/mm². Weld in all position. volatile slag.

ELECTRODES IDENTIFICATION ACCORDING TO A.W.S. STANDARDS

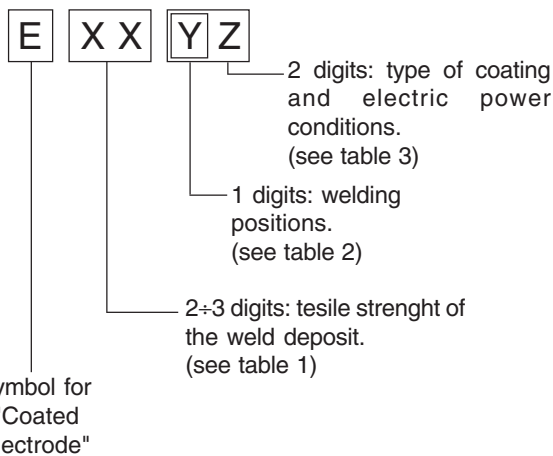

Number	Strength	
	K.s.l.	Kg/mm ²
60	60.000	42
70	70.000	49
80	80.000	56
90	90.000	63
100	100.000	70
110	110.000	77
120	120.000	84

Table 1

1	for all positions
2	for plane and vertical
3	for plane position only

Table 2

N°	Descrizione
10	Cellulose electrodes for d.c.
11	Cellulose electrodes for a.c.
12	Rutile electrode for d.c.
13	Rutile electrode for a.c.
14	High yield rutile electrodes
15	Basic electrodes for d.c.
16	Basic electrodes for a.c.
18	High yield basic electrodes for d.c. (inverse polarity)
20	Acid electrodes for flat or front position welding for d.c. (- pole) and for a.c.
24	High yield rutile electrodes for flat or front plane position welding for d.c. and a.c.
27	High yield acid electrodes for flat or front plane position welding for d.c. (- pole) and a.c..
28	High yield basic electrodes for flat or front plane position welding for d.c. (inverse polarity)
30	Extra high yield acid electrodes, extra high penetration if required, for flat position welding only for d.c. (- pole) and a.c.

Table 3

A	: Alternator	A3	: Insulation monitoring	A6	: Commutator/switch
B	: Wire connection unit	B3	: E.A.S. connector	B6	: Key switch, on/off
C	: Capacitor	C3	: E.A.S. PCB	C6	: QEA control unit
D	: G.F.I.	D3	: Booster socket	D6	: Connector, PAC
E	: Welding PCB transformer	E3	: Open circuit voltage switch	E6	: Frequency rpm regulator
F	: Fuse	F3	: Stop push-button	F6	: Arc-Force selector
G	: 400V 3-phase socket	G3	: Ignition coil	G6	: Device starting motor
H	: 230V 1phase socket	H3	: Spark plug	H6	: Fuel electro pump 12V c.c.
I	: 110V 1-phase socket	I3	: Range switch	I6	: Start Local/Remote selector
L	: Socket warning light	L3	: Oil shut-down button	L6	: Choke button
M	: Hour-counter	M3	: Battery charge diode	M6	: Switch CC/CV
N	: Voltmeter	N3	: Relay	N6	: Connector – wire feeder
P	: Welding arc regulator	O3	: Resistor	O6	: 420V/110V 3-phase transformer
Q	: 230V 3-phase socket	P3	: Sparkler reactor	P6	: Switch IDLE/RUN
R	: Welding control PCB	Q3	: Output power unit	Q6	: Hz/V/A analogic instrument
S	: Welding current ammeter	R3	: Electric siren	R6	: EMC filter
T	: Welding current regulator	S3	: E.P.4 engine protection	S6	: Wire feeder supply switch
U	: Current transformer	T3	: Engine control PCB	T6	: Wire feeder socket
V	: Welding voltage voltmeter	U3	: R.P.M. electronic regulator	U6	: DSP chopper PCB
Z	: Welding sockets	V3	: PTO HI control PCB	V6	: Power chopper supply PCB
X	: Shunt	Z3	: PTO HI 20 l/min push-button	Z6	: Switch and leds PCB
W	: D.C. inductor	W3	: PTO HI 30 l/min push-button	W6	: Hall sensor
Y	: Welding diode bridge	X3	: PTO HI reset push-button	X6	: Water heater indicator
		Y3	: PTO HI 20 l/min indicator	Y6	: Battery charge indicator
A1	: Arc striking resistor	A4	: PTO HI 30 l/min indicator	A7	: Transfer pump selector AUT-0-MAN
B1	: Arc striking circuit	B4	: PTO HI reset indicator	B7	: Fuel transfer pump
C1	: 110V D.C./48V D.C. diode bridge	C4	: PTO HI 20 l/min solenoid valve	C7	: "GECO" generating set test
D1	: E.P.1 engine protection	D4	: PTO HI 30 l/min solenoid valve	D7	: Flooting with level switches
E1	: Engine stop solenoid	E4	: Hydraulic oil pressure switch	E7	: Voltmeter regulator
F1	: Acceleration solenoid	F4	: Hydraulic oil level gauge	F7	: WELD/AUX switch
G1	: Fuel level transmitter	G4	: Preheating glow plugs	G7	: Reactor, 3-phase
H1	: Oil or water thermostat	H4	: Preheating gearbox	H7	: Switch disconnect
I1	: 48V D.C. socket	I4	: Preheating indicator	I7	: Solenoid stop timer
L1	: Oil pressure switch	L4	: R.C. filter	L7	: "VODIA" connector
M1	: Fuel warning light	M4	: Heater with thermostat	M7	: "F" EDC4 connector
N1	: Battery charge warning light	N4	: Choke solenoid	N7	: OFF-ON-DIAGN. selector
O1	: Oil pressure warning light	O4	: Step relay	O7	: DIAGNOSTIC push-button
P1	: Fuse	P4	: Circuit breaker	P7	: DIAGNOSTIC indicator
Q1	: Starter key	Q4	: Battery charge sockets	Q7	: Welding selector mode
R1	: Starter motor	R4	: Sensor, cooling liquid temperature	R7	: VRD load
S1	: Battery	S4	: Sensor, air filter clogging	S7	: 230V 1-phase plug
T1	: Battery charge alternator	T4	: Warning light, air filter clogging	T7	: V/Hz analogic instrument
U1	: Battery charge voltage regulator	U4	: Polarity inverter remote control	U7	: Engine protection EP6
V1	: Solenoid valve control PCBT	V4	: Polarity inverter switch	V7	: G.F.I. relay supply switch
Z1	: Solenoid valve	Z4	: Transformer 230/48V	Z7	: Radio remote control receiver
W1	: Remote control switch	W4	: Diode bridge, polarity change	W7	: Radio remote control transmitter
X1	: Remote control and/or wire feeder socket	X4	: Base current diode bridge	X7	: Isometer test push-button
Y1	: Remote control plug	Y4	: PCB control unit, polarity inverter	Y7	: Remote start socket
A2	: Remote control welding regulator	A5	: Base current switch	A8	: Transfer fuel pump control
B2	: E.P.2 engine protection	B5	: Auxiliary push-button ON/OFF	B8	: Ammeter selector switch
C2	: Fuel level gauge	C5	: Accelerator electronic control	C8	: 400V/230V/115V commutator
D2	: Ammeter	D5	: Actuator	D8	: 50/60 Hz switch
E2	: Frequency meter	E5	: Pick-up	E8	: Cold start advance with temp. switch
F2	: Battery charge transformer	F5	: Warning light, high temperature	F8	: START/STOP switch
G2	: Battery charge PCB	G5	: Commutator auxiliary power	G8	: Polarity inverter two way switch
H2	: Voltage selector switch	H5	: 24V diode bridge	H8	: Engine protection EP7
I2	: 48V a.c. socket	I5	: Y/s commutator	I8	: AUTOIDLE switch
L2	: Thermal relay	L5	: Emergency stop button	L8	: AUTOIDLE PCB
M2	: Contactor	M5	: Engine protection EP5	M8	: A4E2 ECM engine PCB
N2	: G.F.I. and circuit breaker	N5	: Pre-heat push-button	N8	: Remote emergency stop connector
O2	: 42V EEC socket	O5	: Accelerator solenoid PCB	O8	: V/A digital instruments and led VRD PCB
P2	: G.F.I. resistor	P5	: Oil pressure switch	P8	: Water in fuel
Q2	: T.E.P. engine protection	Q5	: Water temperature switch	Q8	: Battery disconnect switch
R2	: Solenoid control PCBT	R5	: Water heater	R8	: Inverter
S2	: Oil level transmitter	S5	: Engine connector 24 poles	S8	: Overload led
T2	: Engine stop push-button T.C.1	T5	: Electronic GFI relais	T8	: Main IT/TN selector
U2	: Engine start push-button T.C.1	U5	: Release coil, circuit breaker	U8	: NATO socket 12V
V2	: 24V c.a. socket	V5	: Oil pressure indicator	V8	: Diesel pressure switch
Z2	: Thermal magnetic circuit breaker	Z5	: Water temperature indicator	Z8	: Remote control PCB
W2	: S.C.R. protection unit	W5	: Battery voltmeter	W8	: Pressure turbo protection
X2	: Remote control socket	X5	: Contactor, polarity change	X8	:
Y2	: Remote control plug	Y5	: Commutator/switch, series/parallel	Y8	:

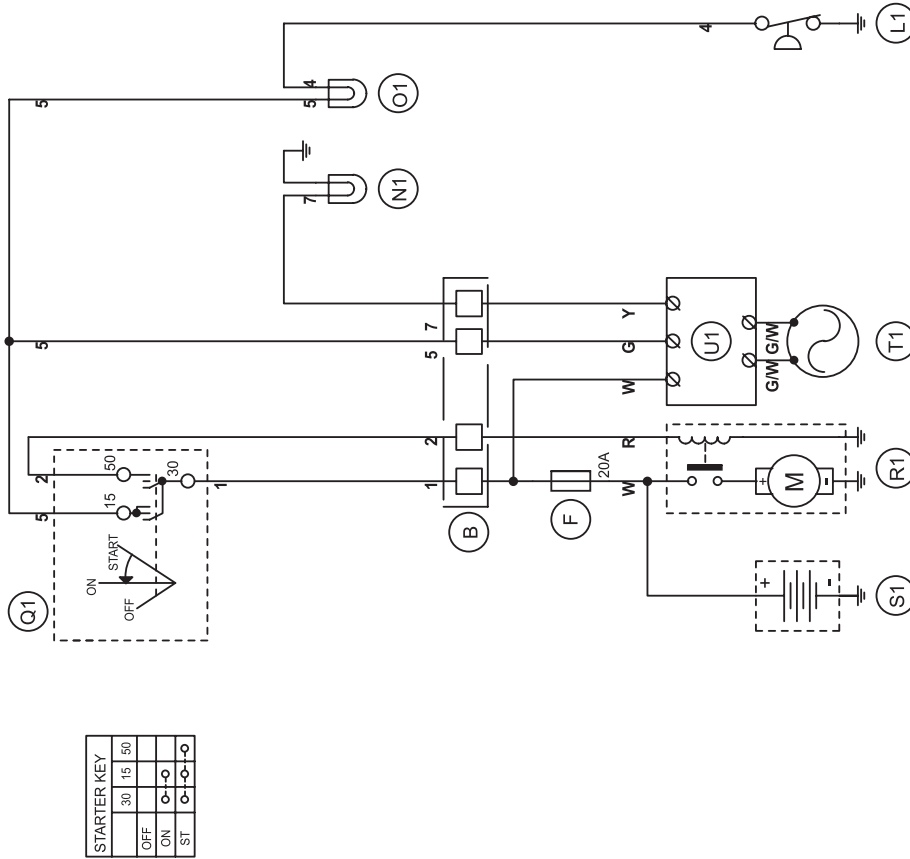

STARTER KEY	
30	50
OFF	
ON	
ST	

A	Modificato schema con nuovo motore completo di avvolg. carica batteria.	29.09.2006	N.L.
Esc. Eqp.	Modifica Modification	Data	Dis. Dis.
	Denominazione: Denomination:	Progetto: Project:	Dis. n.° of n.°
	Da Pag. From Page	25676.prg	2
	Alia Pag. to Page		3
	Disegnatore: Designer:	Dis. n.° of n.°	Approvato: Approved:
	20090-CUSAGO (MI)-ITALY http://www.mosa.it	27.10.2003	25646.S.010-A
	Macchina: Machine:		
	GE 6000 DES/GS		
	Leporace N.		

La MOSA si riserva a termini di legge la proprietà del presente disegno con divieto di riprodurlo o comunicarlo a terzi senza sua autorizzazione.

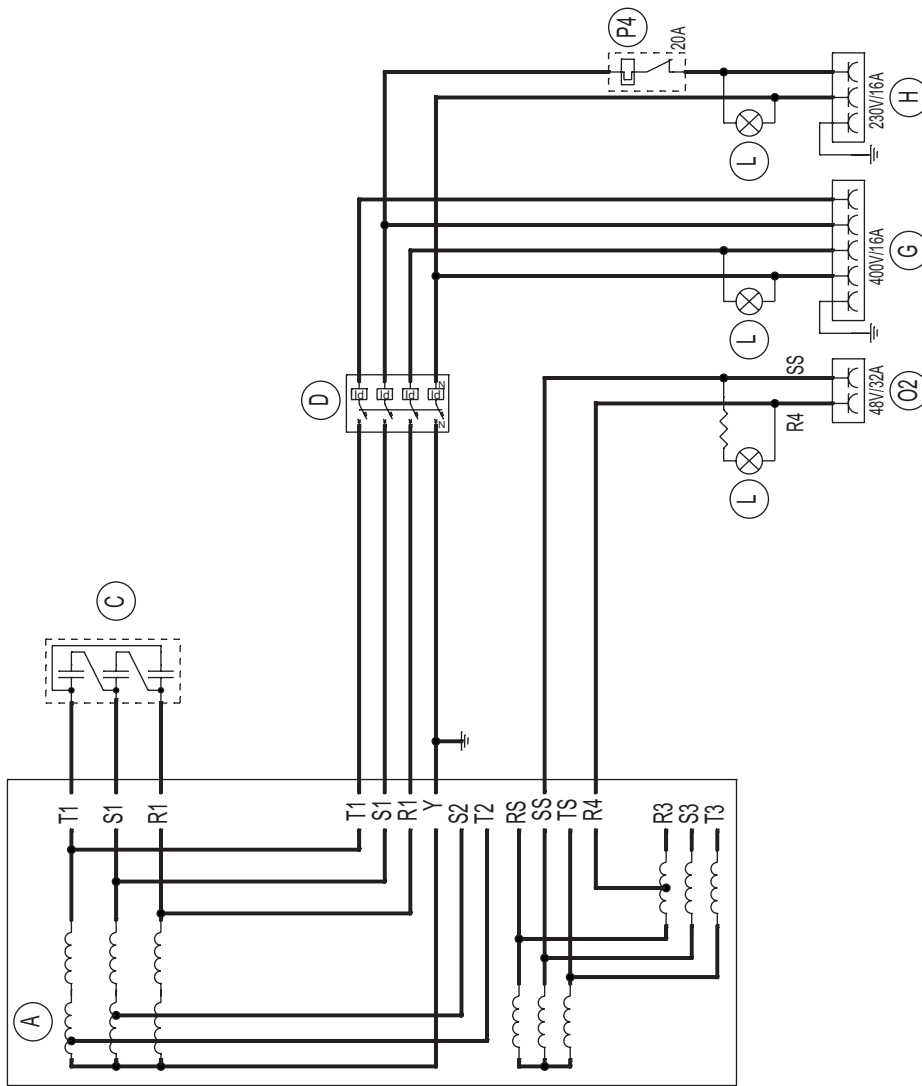

A Sostituito alternatore (A) con nuovo avvolgimento senza carica batteria.		16.11.2006		N.L.	
Esp.:	Modifica:	Data:	Dis.:	Abbr.:	N.L.
Exib.:	Denominazione:	Progetto:	Dis. n.:	Abbr.:	Dis. n.:
	Aux. (400T/230M/48M) DT	27272.prg	27272.S.020-A		27272.S.020-A
	Da Pag.:	Dis. n.:	Dis. n.:	Dis. n.:	Dis. n.:
	From Page:	3	3	3	3
	Alia Pag.:	4	4	4	4
	To Page:				
	Macchina:	Dis. n.:	Dis. n.:	Dis. n.:	Dis. n.:
	TS 200 DES/CF	27272.S.020-A	27272.S.020-A	27272.S.020-A	27272.S.020-A
	Leptorace N.:	01.08.2000	01.08.2000	01.08.2000	01.08.2000
	http://www.mtosa.it				
La MOSA si riserva a termini di legge la proprietà del presente disegno con divieto di riproduzione o comunicazione a terzi senza sua autorizzazione.					

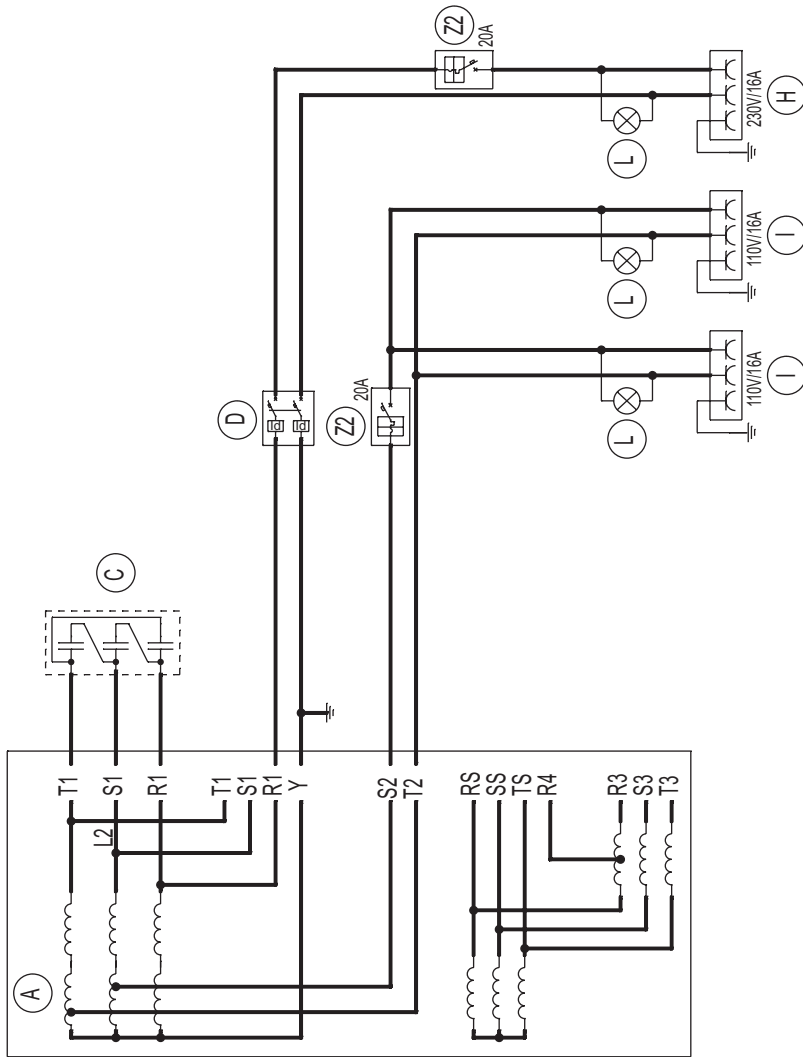

A Sostituito alternatore (A) con nuovo avvolgimento senza carica batteria.		16.11.2006		N.L.	
Esp.:	Modifica	Dis.:	Dis.:	Dis.:	Dis.:
Exp.:	Modification	Desi.:	Desi.:	Desi.:	Desi.:
Da Pag. 1		Progetto: 27273.prg		Pag. n° 3	
From Page 1		Project:		Page n° 4	
Denominazione: Aux. (230M/110CTEx2) DM		Dis. n°: 27273.S.020-A		Approvato: <i>[Signature]</i>	
MOSCA		Date: 01.08.2000		Dwg. n°:	
20090-CUSAGO (MI)-ITALY		Designer: Leporace N.		Approved:	
http://www.mosa.it		Machine: TS 200 DES/CF		Date: 16.11.2006	
La MOSCA si riserva a termini di legge la proprietà del presente disegno con divieto di riproduzione o comunicato a terzi senza sua autorizzazione.					

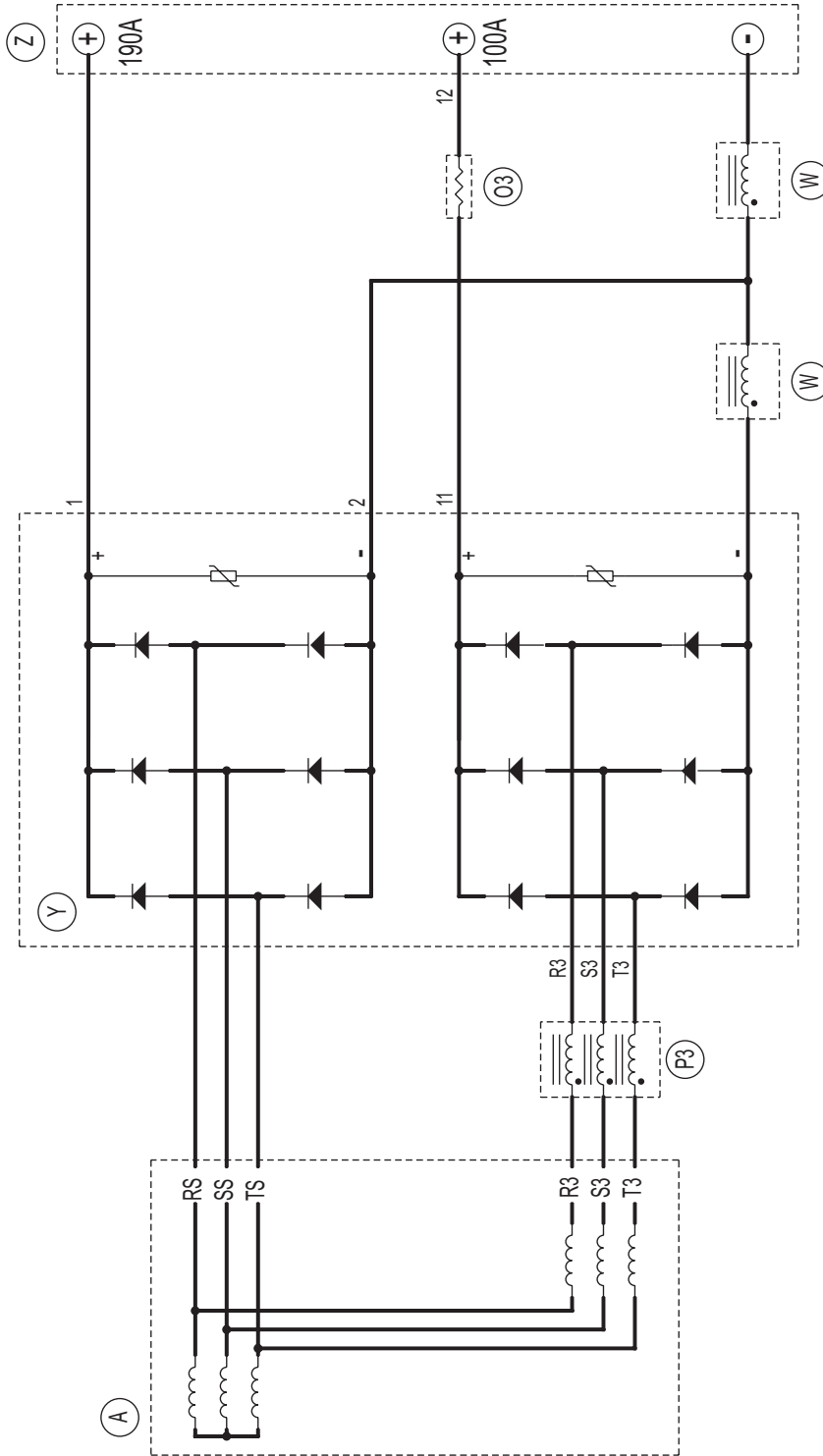

Esp. Exo.	Modifica Modification	Data Date	Dis. Desi.	Appr. Appr.
MOSA	Denominazione: Welding Power	Progetto: 27272.prg	Page n°	di n°
20090-CUSAGO (MI)-ITALY http://www.mosa.it	Macchina: TS 200 DES/CF	Dis. n°: 27272.S.030	4	4
Designatore: Leporace N.		Date: 01/08/2000	Approvato:	

La MOSA si riserva a termini di legge la proprietà del presente disegno con divieto di riprodurlo o comunicarlo a terzi senza sua autorizzazione

MOSA guarantees that any request for spare parts will be satisfied.

To keep the machine in full working order, when replacement of MOSA spare parts is required, always ask for genuine parts only.

 The requested data are to be found on the data plate located on the machine structure, quite visible and easy to consult. *

When ordering the spare parts, it is recommended to indicate:

- 1) * serial number
- 2) * model of welder and/or generating set
- 3) ◆ n. table
- 4) ◆ n. position
- 5) quantity

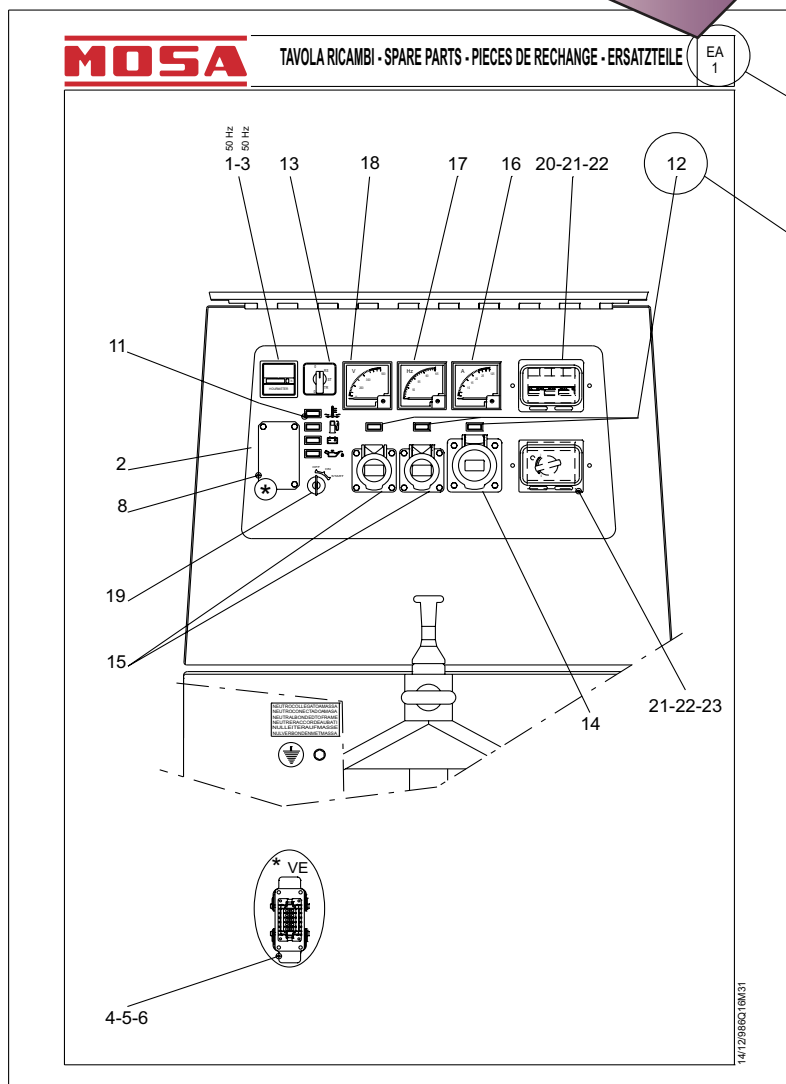
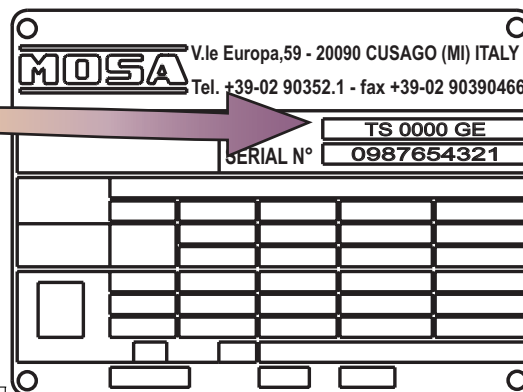

ABBREVIATIONS AND SYMBOLS:

- (EV) When ordering, specify the engine type and the auxiliary voltage
- (ER) Engine with recoil starter only
- (ES) Engine with electric starter only
- (VE) E.A.S version only.
- (QM) When ordering, specify the length in meters
- (VS) Special version only
- (SR) By request only

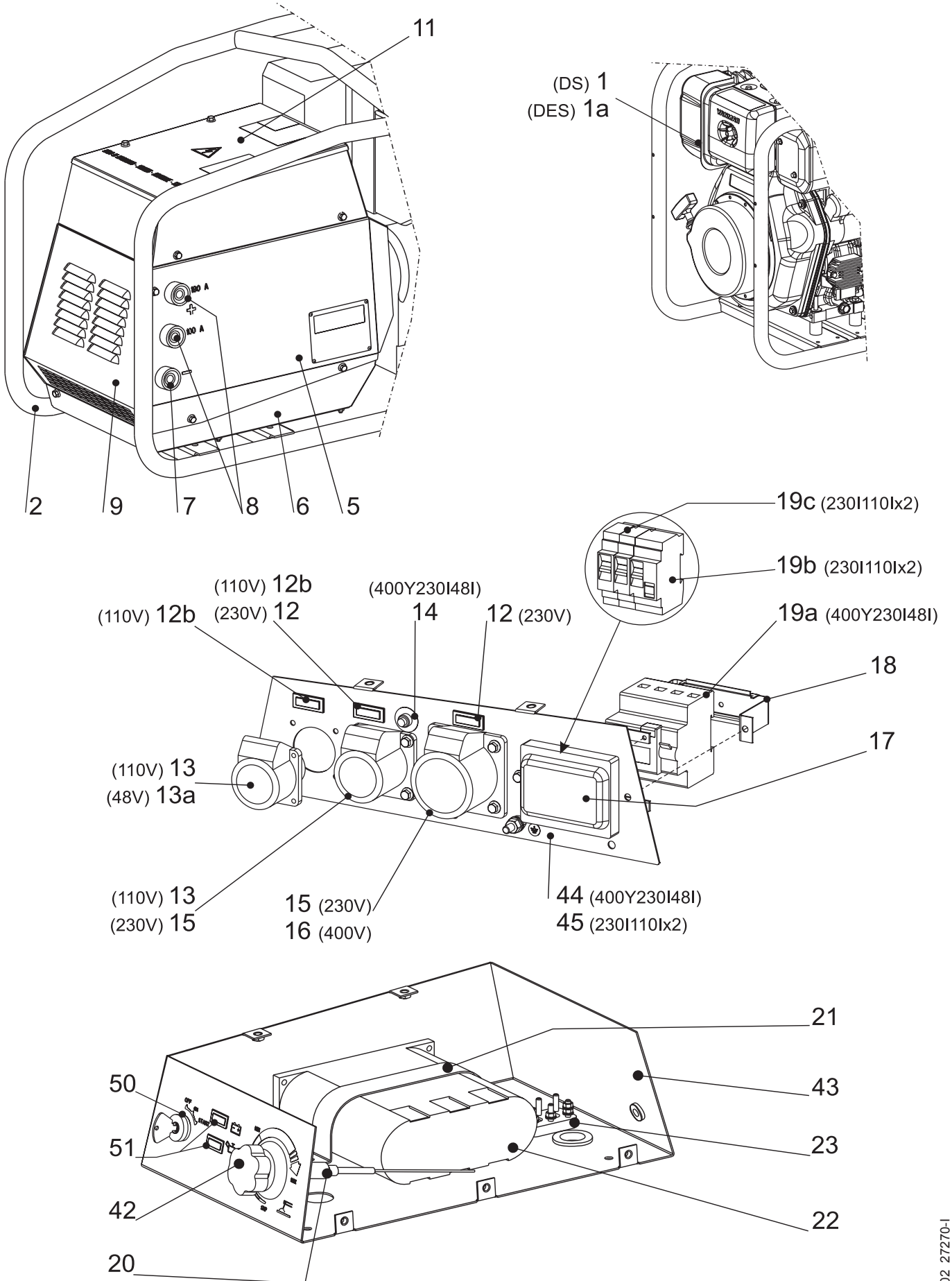

Pos.	Cod.	Descr.	Note
1	M272702200	MOTORE YANMAR L100AE-DG / YANMAR ENGINE L100AE-DG	Fino a/Up to REV.1-04/07 Del. 12/09 - 17/02/09
1	M256752200	MOTORE YANMAR L100N / YANMAR ENGINE L100N	Dal/From REV.2-02/11 Del. 12/09 - 17/02/09
1a	M272722200	MOTORE YANMAR L100AE-DEG / YANMAR ENGINE L100AE-DEG	Fino a /Up to REV.0-11/02 Del. 202/06 - 20/11/06
1a	M256862200	MOTORE YANMAR L100AE-DEG / YANMAR ENGINE L100AE-DEG	Dal/From REV.1-04/07 Del. 202/06 - 20/11/06
			Fino a/Up to REV.1-04/07 Del. 285 - 11/01/08
1a	M256762200	MOTORE YANMAR L100N / YANMAR ENGINE L100N	Dal/From REV.2-02/11 Del. 285/07 - 11/01/08
2	M272701050	BARELLA / PROTECTIVE FRAME	
5	M272708005	CARENATURA / FRAME	
6	M272708205	SCATOLA DI BASE / CASE, BOTTOM HALF	
7	M102044400	PRESA DI SALDATURA (-) / WELDING SOCKET (-)	
8	M102301310	PRESA DI SALDATURA (+) / WELDING SOCKET (+)	
9	M272708235	GRIGLIA DI ASPIRAZIONE / NTAKE GRATE	
11	M272707015	COPERCHIO SCATOLA ELETTRICA / COVER ELECTRICAL BOX	
12	M1302220	SPIA 220V / WARNING LIGHT 230V	Fino a/Up to REV.1-04/07 Del.52/08 - 03/03/08
12	M1302530	SPIA 220V / WARNING LIGHT 220V	Dal/From REV.2-02/11 Del. 52/08 -03/03/08
12b	M1302160	SPIA 110V / WARNING LIGHT 110V	Fino a/Up to REV.1-04/07 Del.52/08 - 03/03/08
12b	M1302520	SPIA 110V / WARNING LIGHT110V	Dal/From REV.2-02/11 Del.52/08 - 03/03/08
13	M307047250	PRESA 110V 16A / EEC SOCKET 110V 16A 2 P+N	
13a	M218137280	PRESA CEE 48V 32A / EEC SOCKET 48V 32A	
14	M306467107	PROTEZIONE TERMICA (AUX) / THERMOPROTECTION 20AMP 250 V	
15	M307017240	PRESA 220V 16A / EEC SOCKET 16A, 220V 2P+T	
16	M305907270	PRESA CEE 16A 400V 3P+N+T / EEC SOCKET 16A 400V 3P+N+T	
17	M219937130	COPERCHIO INTERRUPT.DIFFERENZ. / COVER GFI	
18	M219937036	STAFFA / BRACKET	
19a	M105111540	INTERRUTTORE DIFFERENZIALE / GROUNDFAULT INTERRUPTOR (GFI)	vers. 400/230/48
19b	M220237105	INTERRUTTORE DIFFERENZIALE / GROUNDFAULT INTERRUPTOR	vers. 230/110/110
19c	M105277325	INTERRUTTORE MAGNETOTERMICO / CIRCUIT BREACKER	vers. 230/110/110
20	M309049105	COMANDO ACCELERATORE MOTORE / ENGINE ACCELLERATOR CONTROL	era/was 272709105
21	M307017037	STAFFA / BRACKET	
22	M307809880	BOX CONDENSATORI 3x80 UF / CAPACITOR BOX 3X80 UF	
23	M218017226	MORSETTIERA / TERMINAL BOARD	
42	M109019702	MANOPOLA / HAND GRIP	
43	M272707010	SCATOLA ELETTRICA / ELECTRICAL BOX	
44	M272707020	PANNELLO FRONTALE / FRONT PANEL	vers. 400/230/48
45	M272717020	PANNELLO FRONTALE / FRONT PANEL	vers. 230/110/110
50	M107302460	INTERRUTTORE ACCENS. A CHIAVE / STARTER KEY	Dal/From REV.1-04/07 Del. 202/06 - 20/11/06
51	M1302040	SPIA 12V ROSSA / RED WARNING LIGHT 12V	Dal / From REV.1-04/07 Del. 202/06 - 20/11/06
			Fino a/Up to REV.1-04/07 Del. 52/08 - 03/03/08
51	M1302500	SPIA 12V ROSSA / RED WARNING LIGHT 12V	Dal / From REV.2-02/11 Del. 52/08 - 03/03/08

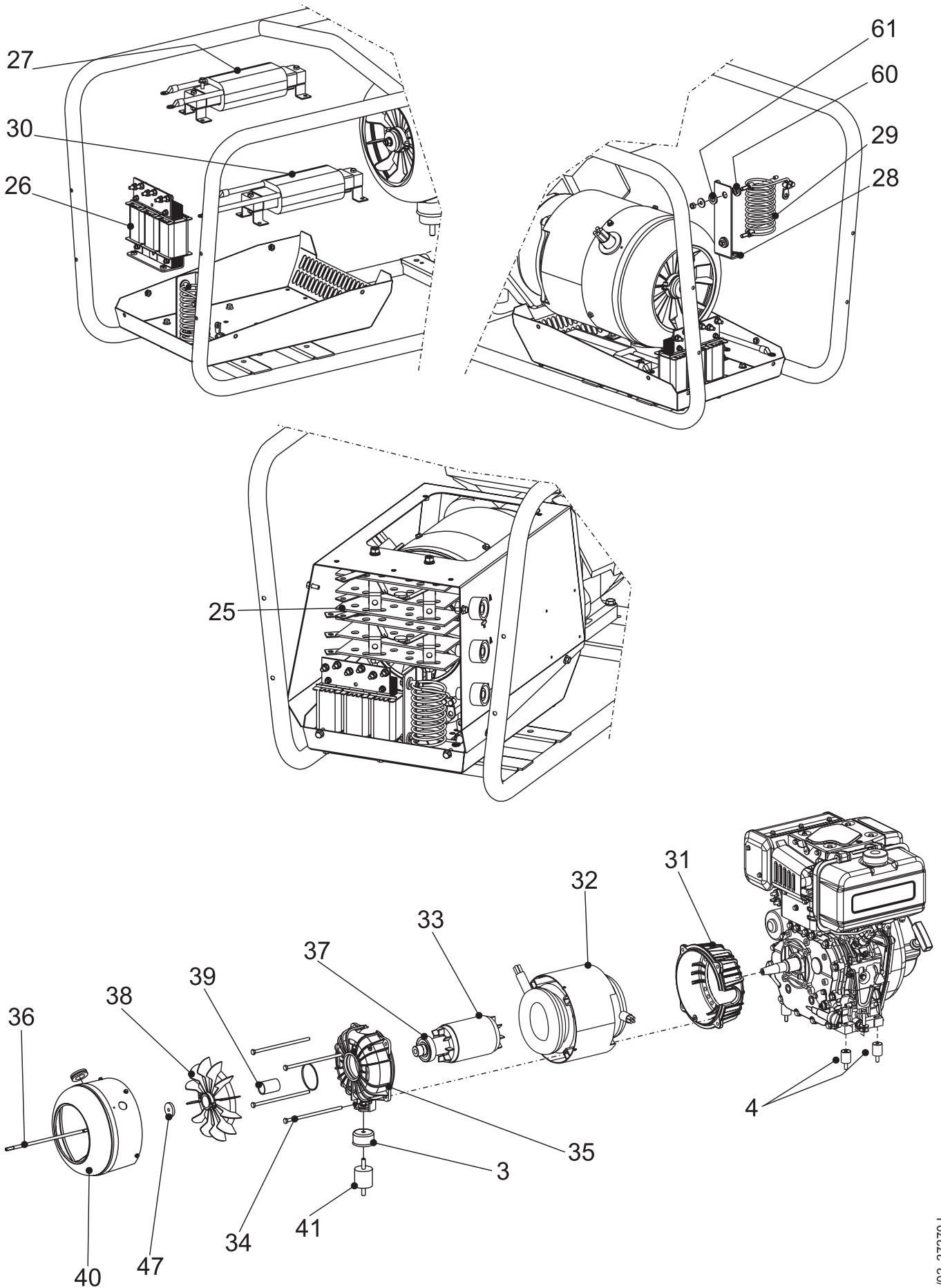

Pos.	Rev.	Cod.	Descr.	Note
3		M307012037	PROTEZIONE ANTIVIBRANTE	
4	B	M222401035	ANTIVIBRANTE	era 256011035
25		M272705100	PONTE DIODI	
26		M272704120	REATTORE TRIFASE	
27		M272704100	REATTORE DI LIVELLO	
28		M271704020	SUPPORTO	
29		M271704010	RESISTORE	
30		M220014100	REATTORE COMPLETO	
31		M232123040	FLANGIA ATTACCO MOTORE	
32		M272703025	STATORE AVVOLTO	Fino a REV.1-11/06 Del. 202/06 - 20/11/06
32		M272723025	STATORE AVVOLTO	Da REV.2-04/07 Del. 202/06 - 20/11/06
33		M232123030	ALBERO CON ROTORE	
34		M107011280	TIRANTE	
35		M105913045	FLANGIA PORTA ALTERNATORE	
36		M232123036	TIRANTE	
37		M1001030	CUSCINETTO	
38		M105111290	VENTOLA CON FASCETTA	
39		M105311370	DISTANZIALE	
40	B	M272506010	CONVOGLIATORE ARIA	era 271706010
41		M105112020	ANTIVIBRANTE	
47		M105311380	RONDELLA	Fino a REV.0-10/98 Del. 91/06 - 07/06/06 07/06/06
47		M356403038	RONDELLA Da REV.1-11/06 Del. 91/06 del	
50		M107302460	STARTER A CHIAVE	vers.DES-Fino a REV.1-11/06 Del. 202/06 - 20/11/06
51		M1302040	SPIA 12V	vers.DES-Fino a REV.1-11/06 Del. 202/06 - 20/11/06
52		M256027060	PANNELLO	vers.DES-Fino a REV.1-11/06 Del. 202/06 - 20/11/06
53		M155307107	DISGIUNTORE TERMICO	vers.DES-Fino a REV.1-11/06 Del. 202/06 - 20/11/06
54		M256022275	REGOLATORE DI TENSIONE	vers.DES-Fino a REV.1-11/06 Del. 202/06 - 20/11/06
55		M256027059	SCATOLA SUPPORTO REGOLATORE	vers.DES-Fino a REV.1-11/06 Del. 202/06 - 20/11/06
60	B	M107815043	BOCCOLA ISOLANTE	
61	B	M107814013	RONDELLA ISOLANTE	
				Note
3		M307012037	PROTECTION, VIBRATION-DAMPER	
4	B	M222401035	VIBRATION DAMPER	was 256011035
25		M272705100	DIODE BRIDGE ASSY	
26		M272704120	REACTOR	
27		M272704100	LEVEL REACTOR	
28		M271704020	SUPPORT	
29		M271704010	RESISTOR	
30		M220014100	COMPLETE REACTOR	
31		M232123040	FLANGE FIXING ENGINE	
32		M272703025	STATOR	Up to REV.1-11/06 Del. 202/06 - 20/11/06
32		M272723025	STATOR	From REV.2-04/07 Del. 202/06 - 20/11/06
33		M232123030	SHAFT WITH ROTOR	
34		M107011280	TIE - ROD	
35		M105913045	FLANGE, ALTERNATOR HOLDER	
36		M232123036	TIE-ROD	
37		M1001030	BEARING	
38		M105111290	FAN	
39		M105311370	SPACER	
40	B	M272506010	AIR DUCT	was 271706010
41		M105112020	VIBRATION DAMPER	
47		M105311380	WASHER	Up to REV.0-10/98 Del. 91/06 - 07/06/06
47		M356403038	WASHER	From REV.1-11/06 Del. 91/06 - 07/06/06
50		M107302460	STARTER KEY	vers.DES-Up to REV.1-11/06 Del. 202/06 - 20/11/06
51		M1302040	RED WARNING LIGHT 12V	vers.DES-Up to REV.1-11/06 Del. 202/06 - 20/11/06
52		M256027060	PANEL	vers.DES-Up to REV.1-11/06 Del. 202/06 - 20/11/06
53		M155307107	THERMAL SWITCH 15A-250V	vers.DES-Up to REV.1-11/06 Del. 202/06 - 20/11/06
54		M256022275	VOLTAGE REGULATOR	vers.DES-Up to REV.1-11/06 Del. 202/06 - 20/11/06
55		M256027059	BOX, SUPPORT REGULATOR	vers.DES-Up to REV.1-11/06 Del. 202/06 - 20/11/06
60	B	M107815043	BUSH	
61	B	M107814013	WASHER	

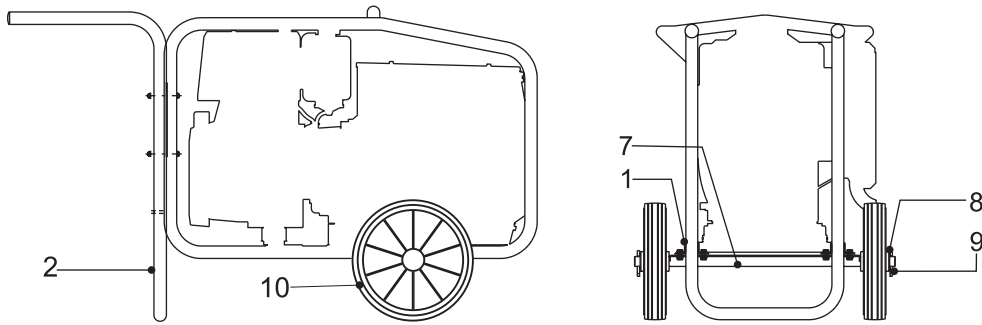

Pos.	Rev.	Cod.	Descr.	Descr.	Note
1		107012150	CAVALLOTTO	U-BOLT	
2		107012130	MANIGLIA	HANDLE	
7		205311160	ASSALE	AXLE	
8		205311180	RONDELLA	WASHER	
9		6075020	COPIGLIA	PIN, SPLIT	
10		105311650	RUOTA	WHEEL	

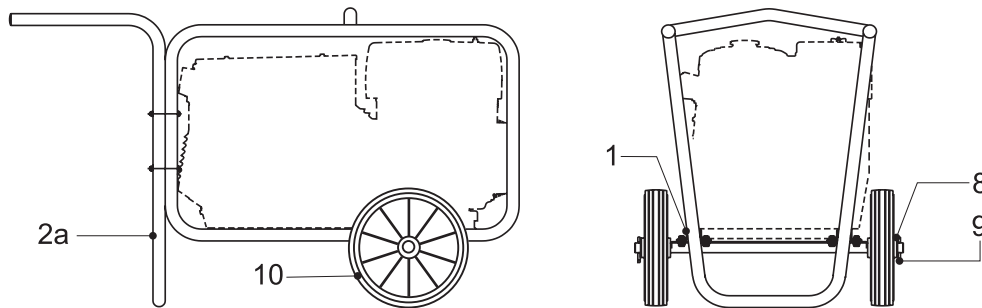

Pos.	Rev.	Cod.	Descr.	Descr.	Note
1		107012150	CAVALLOTTO	U-BOLT	
2a		208101051	MANIGLIA	HANDLE	
7		205311160	ASSALE	AXLE	
8		205311180	RONDELLA	WASHER	
9		6075020	COPIGLIA	PIN, SPLIT	
10		105311650	RUOTA	WHEEL	

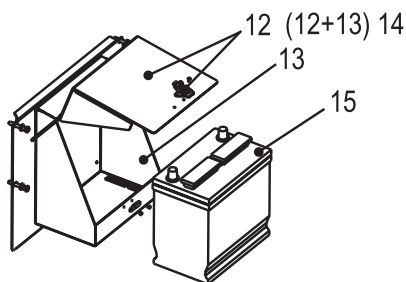

Pos.	Cod.	Descr.	Descr.	Note
12	256020549	GR.COPERCHIO COMPLETO	COMPLETE COVER	
13	256029168	CESTELLO PORTABATTERIA	BATTERY HOLDER	
14	256029160	CESTELLO P/BATT.+COPERCHIO	BATTERY HOLDER WITH COVER	
15	209509150	BATTERIA	BATTERY	(fino a/up to REV.0 04/97 Del. 74/05 del 15/07/05)
15	372859150	BATTERIA	BATTERY	(da/from REV.1 10/05 Del. 74/05 del 15/07/05)

MOSA

GRUPPI ELETTROGENI

MOTOSALDATRICI

WWW.MOSA.IT

MOSA div. della BCS S.p.A.
Stabilimento di Viale Europa, 59
20090 Cusago (MI) Italia

Tel. + 39 - 0290352.1
Fax + 39 - 0290390466



ISO 9001:2008 - Cert. 0192