



GENERATING SET GE S-6500 YDT

The images are for reference



FEATURES

- Manual recoil (AA)
- Low oil pressure automatic engine shut down
- Sockets: 1x 400V 16A 3P+N+T CEE
1x 230V 16A 2P+T CEE
1x 230V 16A 2P+T Schuko
- Circuit breaker
- Fuel level gauge
- Protective frame and partially covered
- Not compliant with noise directive 2000/14/EC
- AVR version **on request**
- Electric Starter **on request** (AE)



air cooled



diesel



three-phase



manual
recoil



electric
start



silenced

POWER RATINGS

* Stand-By three-phase power (LTP)	6.5 kVA (5.2 kW) / 400V / 9.4A
* PRP three-phase power	5.7 kVA (4.6 kW) / 400V / 8.2A
* PRP single-phase power	4 kVA / 230V / 17.4A
* COP single-phase power	/
Frequency	50 Hz
Cos φ	0.8

* Output powers according to ISO 8528-1

DEFINITION

Valid declared powers up to the followings environmental conditions: temperature 25°C, altitude 100 meters above sea level

LTP power: stand-by power: Maximum available power for use with variable loads for a yearly number of hours limited at 500 h. No overload is admitted.

PRP power: continue power with variable loads. Maximum power for use with variable loads for a yearly unlimited numbers of hours.

COP power: continuous power with constant load. Maximum power for use with constant loads for a yearly unlimited numbers of hours.

ENGINE 3000 RPM

4 STROKE OHV, NATURAL ASPIRATED

Model	YANMAR L100V
* Stand-By net power	6.3 kWm (8.5 hp)
* PRP net power	5.7 kWm (7.7 hp)
* COP net power	/
Cylinders / Displacement	1 / 435 cm ³
Bore / Stroke	86 / 75 (mm)
Compression ratio	20 : 1
BMEP (Brake Mean Effective Pressure : LTP - PRP)	/
Speed governor type	Mechanical
FUEL CONSUMPTION	
110 % (Stand-by power)	1.5 lt./h
100 % to PRP	1.3 lt./h
75 % to PRP	1 lt./h
50 % to PRP	0.8 lt./h
COOLING SYSTEM	
Total system cap. - only engine	/
Fan air flow	/
LUBRICATION SYSTEM	
Total oil system capacity	/
Oil capacity in sump	1.6 lt.
Oil consumption at full load	/

* Output powers according to ISO 3046-1

EXHAUST SYSTEM

Maximum exhaust gas flow	/
Max. exhaust gas temp.	/
Maximum back pressure	4.3 kPa
External diameter exhaust pipe	/
ELECTRICAL SYSTEM	
Starter motor power	0.8 kW
Battery charging alternator cap.	15 A
Cold start	0°C
With cold start aid	/
AIR FILTER	
Combustion air flow	/
HEAT REJECTED AT FULL LOAD	
To exhaust system	/
To water and oil	/
Radiated to room	/
To charge cooler	/

ALTERNATOR

SYNCHRONOUS, THREE-PHASE, SELF-EXCITED, SELF-REGULATED		
	WITHOUT AVR	WITH AVR
Continuous power	7 kVA	
Stand-by power	7.7 kVA	
Three phase voltage	400 Vac	
Frequency	50 Hz	
Cos φ	0.8	
Model A.V.R.	/	HVR10
Voltage regulation acc.	± 4 %	± 1 %
Sustained short circuit current	3 In	
Transient dip (100% load)	< 15 %	
Recovery time	/	
Efficiency at 100% load	80.5% (400V - Cosφ 0.8)	82.5 % (400V - Cos φ 0.8)
Insulation	Class H	
Connection - Terminals	Series - N°6	
Electromagnetic compatibility (R.F.I. suppr.)	EN55011	
Waveform distortion - THD	< 4 %	
Telephone interference - THF	/	

REACTANCES (7 KVA - 400 V) REACTANCES AVR (7 KVA - 400 V)	WITHOUT AVR	WITH AVR
Direct axis synchronous - Xd	270 %	222 %
Direct axis transient - X'd	20 %	15 %
Subdirect axis transient - X''d	6.5 %	4.7 %
Quadrature axis synchronous - Xq	150 %	128 %
Quadr. axis subtransient - X''q	/	/
Negative sequence - X2	/	/
Zero sequence - X0	/	/
TIME CONSTANTS		
Transient - T'd	33 ms	33 ms
Subtransient - T''d	5.5 ms	6 ms
Open circuit - T'do	450ms	500 ms
Armature - Ta	/	/
Short-circuit ratio Kcc	0.60	0.72
IP protection degree	IP 23	
Cooling air flow	0.062/ m³/sec	0.060/ m³/sec
Coupling I Bearing	Direct J609b - N°1	

GENERAL SPECIFICATIONS

Fuel tank capacity	20 lt.
Running time (75% to PRP)	20 h
Starter battery	12 Vdc -18Ah (AE)
IP protection degree	IP 23

Acoustic power LwA (pressure LpA)	99 dB(A) (74 dB(A) @ 7m)
Performance class (ISO 8528)	G2

CONTROL PANEL

- Start and stop engine key (AE)
- Low oil pressure shutdown light (AE)
- Battery charge warning light fault (AE)
- Local-Remote Start switch (AE)
- EAS plug (AE)
- Digital multifunction meter: Voltmeter - Frequncymeter -Total Hoursmeter - Partial Hoursmeter (resettable)
- Fuel gouge
- Fuel valve
- Circuit breaker
- Output sockets: 1x 400V 16A 3P+N+T CEE
1x 230V 16A 2P+T CEE
1x 230V 16A 2P+T Schuko
- Earth terminal (PE)

WEIGHT - DIMENSIONS AND ACCESSORIES

GE S-6500 YDT



DRY WEIGHT MACHINE:

- 127 Kg (AA)
- 131 Kg (AVR AA)
- 137 Kg (AE)
- 141 Kg (AVR AE)

Generating set pictured may include optional accessories.



DIMENSIONS DRAW (mm)

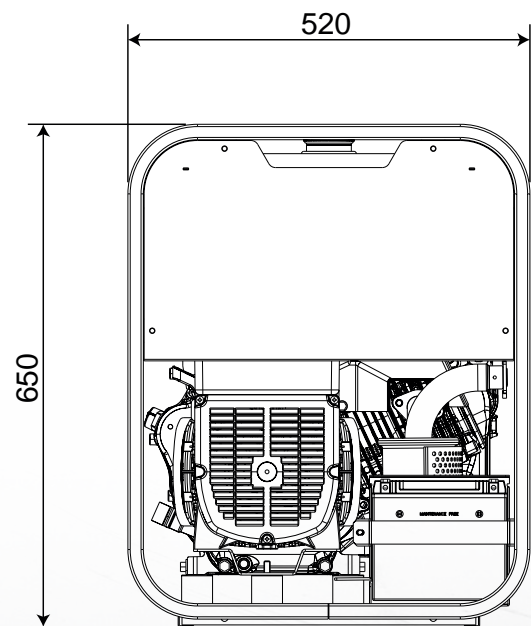
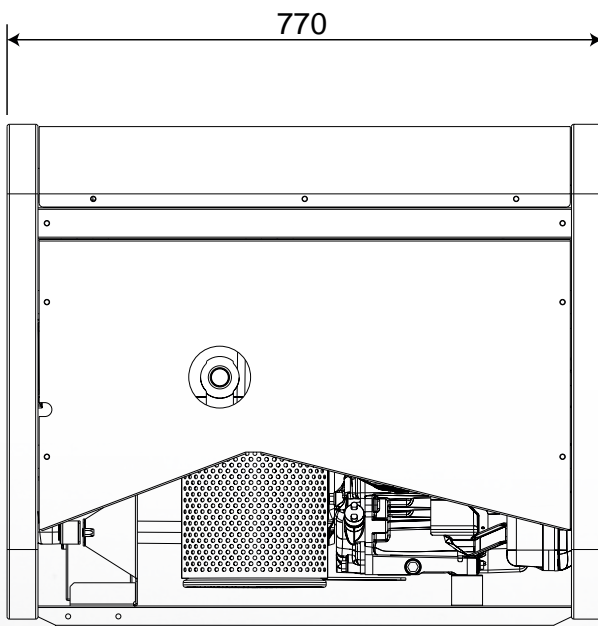

OPTIONS ON REQUEST

- Automatic transfer unit EAS 15 - 806 (AE)
- Remote control
- Earthing kit
- Moving trolley CM8



VERSIONS ON REQUEST

- AVR version
- Electric starter version



FACTORY INSTALLATION OPTIONS

- ELCB-GFI (Ground Fault Interruptor)
- Isometer

GENERAL INFORMATION

COMPLIANCE GENERATING SETS WITH EC DIRECTIVES AND STANDARDS

- 2006/42 / EC (Machines Directive)
- 2014/35 / EU (Low Voltage Directive)
- 2014/30 / EU (EMC Directive)
- ISO 8528 (Reciprocating internal combustion engine driven alternating current generating sets)



ISO 9001:2008 - Cert. 0192

WARRANTY

All devices are covered by the manufacturer's warranty.

Non-contractual document. Specification subject to change without notice.

© MOSA - Viale Europa, 59 - 20047 Cusago (Milano) - Italy - phone +39-0290352.1 - fax + 39-0290390466 E-mail: export@mosa.it Web site: www.mosa.it

