

# GENERATING SET GE 17054 HBT

The images are for reference



## FEATURES

- Honda iGX engine with electronic speed control
- Electronic injection
- Automatic Starter (Auto- Choke)
- Auto-Idle function as standard
- Electronic voltage regulation "AVR"
- Brushless alternator with degree of protection IP 54
- Isolation monitor
- Switch magnetermic
- Differential switches
- Compliant with German Regulation DGUV-I 203-032
- Not compliant with noise directive 2000/14/EC



air cooled



petrol



three-phase power



electric start

POWER RATINGS	
* Stand-By three-phase power (LTP)	17 kVA (13.6 kW) / 400 V / 24.5 A
* PRP three-phase power	15 kVA (12 kW) / 400 V / 21.6 A
* PRP single-phase power	7 kVA/kW / 230 V / 30.4A
Frequency	50 Hz
Cos φ	0.8

\* Output powers according to ISO 8528-1

## DEFINITION

Valid declared powers up to the followings environmental conditions: temperature 25°C, altitude 100 meters above sea level)

**LTP power: stand-by power:** Maximum available power for use with variable loads for a yearly number of hours limited at 500 h. No overload is admitted.

**PRP power:** continue power with variable loads. Maximum power for use with variable loads for a yearly illimited nubers of hours.

**COP power:** continuous power with constant load. Maximum power for use with constant loads for a yearly unlimited numbers of hours.

## ENGINE 3000 RPM

4 STROKE OHV, NATURAL ASPIRATED	
Model	HONDA iGX 800
* Stand-By net power	16.8 kWm (22.8 hp)
* PRP net power	13.3 kWm (18 hp )
* COP net power	/
Cylinders / Displacement	2 a V / 779 cm <sup>3</sup> (0.779 lt.)
Bore / Stroke	83 / 72 (mm)
Compression ratio	9.1 : 1
BMEP (Brake Mean Effective Pressure : LTP - PRP)	/
Speed governor type	Electronic
<b>FUEL CONSUMPTION</b>	
110 % (Stand-by power)	6.9 lt./h
100 % to PRP	6.3 lt./h
75 % to PRP	4.7 lt./h
50 % to PRP	3.2 lt./h
<b>COOLING SYSTEM</b>	
Total system cap. - only engine	/
Fan air flow	/
<b>LUBRICATION SYSTEM</b>	
Total oil system capacity	/
Oil capacity in sump	2 lt.
Oil consumption at full load	/

EXHAUST SYSTEM	
Maximum exhaust gas flow	/
Max. exhaust gas temp.	/
Maximum back pressure	/
External diameter exhaust pipe	/
<b>ELECTRICAL SYSTEM</b>	
Starter motor power	/
Battery charging alternator cap.	20 A
Cold start	/
With cold start aid	/
<b>AIR FILTER</b>	
Combustion air flow	/
<b>HEAT REJECTED AT FULL LOAD</b>	
To exhaust system	/
To water and oil	/
Radiated to room	/
To charge cooler	/



## ALTERNATOR

SYNCHRONOUS, THREE-PHASE, SELF-EXCITED, SELF-REGULATED	
Continuous power	15 kVA
Stand-by power	16.5 kVA
Three phase voltage	380 - 415 Vac
Frequency	50 Hz
Cos φ	0.8
Model A.V.R.	Analogic
Voltage regulation acc.	± 1 %
Sustained short circuit current	3 In
Transient dip (100% load)	< 25 %
Recovery time	< 0.5 sec.
Efficiency at 100% load	/
Insulation	Class F/H
Connection - Terminals	Star (with N) - N°4
Electromagnetic compatibility ( R.F.I. suppr.)	EN 61000-6-2 EN 61000-6-3
Waveform distortion - THD	< 5%
Telephone interference - THF	/

REACTANCES (15 kVA - 400 V)	
Direct axis synchronous - Xd	/
Direct axis transient - X'd	/
Subdirect axis transient - X''d	/
Quadrature axis synchronous - Xq	/
Quadr. axis subtransient - X''q	/
Negative sequence - X2	/
Zero sequence - X0	/
TIME CONSTANTS	
Transient - T'd	/
Subtransient - T''d	/
Open circuit - T'do	/
Armature - Ta	/
Short-circuit ratio Kcc	/
IP protection degree	IP 54
Cooling air flow	/
Coupling   Bearing	Direct - N°1

## GENERAL SPECIFICATIONS

Fuel tank capacity	18 lt.
Running time (75% to PRP)	3.8 h
Starter battery	12 Vdc -37Ah / 330A CCA(EN)

IP protection degree	IP 54
Acoustic power LwA (pressure LpA)	99 dB(A) (74 dB(A) @ 7m)
Performance class (ISO 8528)	G2

## CONTROL PANEL

- Starter key
- Oil alert warning light (led)
- Hour meter
- Fuel tap
- Auto-Idle switch
- voltmeter
- General magnetothermic switch
- Isolation monitor
- Differential-magneto-thermal switch for 230V 16A sockets
- Output sockets: 1x400V 32A 3P + N + T CEE IP67  
2x230V 16A 2P + T Schuko
- Earth terminal (PE)



### AUTOIDLE FUNCTION

Usually petrol gensets are operating at high speed, 3000 rpm.

Experience has taught us that during their use, gensets very often operate with no load. This operation inevitably causes greater fuel consumption and therefore greater environmental pollution and greater noise in the working area.

With **AUTOIDLE** function all this is eliminated, as the engine runs at a low rpm, consequently lower fuel consumption and less noise, and only when current load is requested it automatically goes to the nominal rpm without delays and for any type of load.



# WEIGHT - DIMENSIONS AND ACCESSORIES

GE 17054 HBM



### DRY WEIGHT MACHINE:

- 175 Kg

Generating set pictured may include optional accessories.



### DIMENSIONS DRAW (mm)

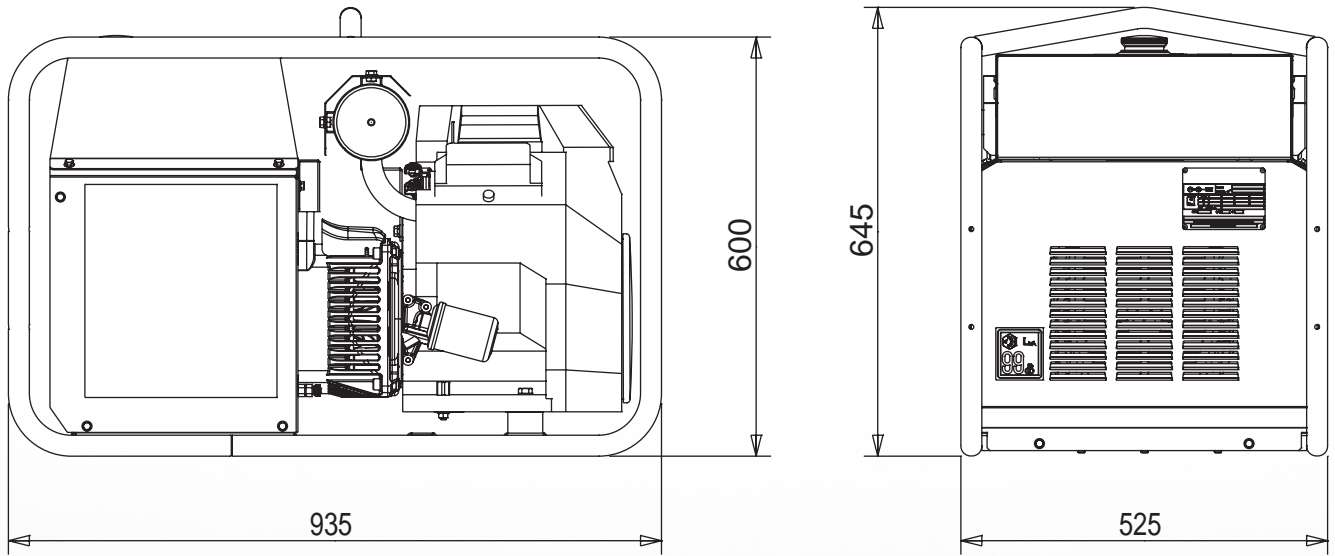

- |   |   |  |
|---|---|--|
| <p><b>+</b> OPTIONS ON REQUEST</p> <ul style="list-style-type: none"> <li>• Earthing</li> <li>• Trolley CTM 10</li> <li>• Tank cap with lock</li> </ul> | <p><b>☀</b> VERSIONS ON REQUEST</p> <ul style="list-style-type: none"> <li>• /</li> </ul> | <p><b>📄</b> FACTORY INSTALLATION OPTIONS</p> <ul style="list-style-type: none"> <li>• /</li> </ul> |
|---|---|--|

## GENERAL INFORMATION

### COMPLIANCE GENERATING SETS WITH EC DIRECTIVES AND STANDARDS

- 2006/42 / EC (Machines Directive)
- 2014/35 / EU (Low Voltage Directive)
- 2014/30 / EU (EMC Directive)
- ISO 8528 (Reciprocating internal combustion engine driven alternating current generating sets )



ISO 9001:2008 - Cert. 0192

### WARRANTY

All devices are covered by the manufacturer's warranty.

**Non-contractual document. Specification subject to change without notice.**

© MOSA - Viale Europa, 59 - 20047 Cusago (Milano) - Italy - phone +39-0290352.1 - fax + 39-0290390466 E-mail: export@mosa.it Web site: www.mosa.it

