



GENERATING SET GE 145 BSX



POWER RATINGS

* Stand-By three-phase power (LTP)	143 kVA (114,4 kW) / 400V / 206,4A
* PRP three-phase power	130 kVA (104 kW) / 400V / 187,6A
* PRP single-phase power	/
Frequency	50 Hz
Cos φ	0.8

* Output powers according to ISO 8528-1

FEATURES

- Electronic regulation of engine speed
- Fuel pre-filter and filter with indicator of the presence of water in the fuel
- Anti-tipping side pockets for handling with forklifts
- Central lifting hook
- Rounded edges to allow rainwater to flow
- Sealed base capable of containing any leaks of liquids present in the engine, avoiding environmental pollution
- Large capacity steel tank
- Large access doors to allow easy maintenance (replacing air, oil, fuel filters)
- Door with viewing porthole for the control panel
- External access for filling the radiator
- External cap for draining liquids in the base
- Oil extraction pump
- 3-way valve for transferring fuel from an external tank with quick filling connections housed in a special niche (OPTIONAL)
- Swinging rain cover at the exhaust gas outlet
- Low level of noise emissions
- Fuel level sensors, low radiator fluid level and crankcase leak detection
- Battery disconnect switch
- Emergency button
- Power cable connection terminal block
- Electrical distribution panel with three-phase and single-phase output sockets
- General four-pole thermomagnetic switch
- Electronic differential relay adjustable in current and trip time as standard with the electrical distribution panel
- Alternator with electronic voltage regulation "AVR" with three-phase sensing
- Alternator windings protected with marine impregnation
- Complies with regulation 2016/1628/EU FOR STATIONARY USE ONLY



water cooled



diesel



three-phase



electric starter

ENGINE 1500 RPM

4 STROKE, DIRECT INJECTION, TURBOCHARGED

Model	BAUDOUIN 4M12G2D3/5
* Stand-By net power	133 kW (180,9 hp)
* PRP net power	120 kW (163,2 hp)
* COP net power	/
Cylinders / Displacement	4 / 4580 cm ³ (4.58 lt.)
Bore / Stroke	108 / 125 (mm)
Compression ratio	16,9 : 1
BMEP (Brake Mean Effective Pressure : LTP - PRP)	2410 kPa
Speed governor type	Electronic
FUEL CONSUMPTION	
110 % (Stand-by power)	34,35 lt./h
100 % to PRP	32,31 lt./h
75 % to PRP	28,11 lt./h
50 % to PRP	19,44 lt./h
25 % to PRP	10,05 lt./h
COOLING SYSTEM	
Total system cap. - only engine	14 lt - 7,12 lt.
Fan air flow	183 m ³ /min.
LUBRICATION SYSTEM	
Total oil system capacity	15 lt, ÷ 17 lt
Oil capacity in sump	/

Oil consumption at full load	0,1 % (consumo carburante)
EXHAUST SYSTEM	
Maximum exhaust gas flow	23,8 m ³ /min.
Max. exhaust gas temp.	720 °C
Maximum back pressure	12 kPa (0,12 bar)
External diameter exhaust pipe	80 mm
ELECTRICAL SYSTEM	
Starter motor power	3,5 kW
Battery charging alternator cap.	35 A
Cold start	-15 °C
With cold start aid	- 24 °C
AIR FILTER	
Air filter	Dry
Combustion air flow	7,53 m ³ /min.
HEAT REJECTED AT FULL LOAD	
To exhaust system	100 kJ /s (100 kW/h)
To water and oil	56,2 kJ /s (56,2 kW/h)
Radiated to room	16,3 kJ /s (16,3 kW/h)
To charge cooler	17,9 kJ /s (17,9 kW/h)

* Output powers according to ISO 3046-1



ALTERNATOR

SYNCHRONOUS, THREE-PHASE, SELF-EXCITED, SELF-REGULATED, BRUSHLESS

Continuous power	130 kVA
Stand-by power	147 kVA
Three phase voltage	380 - 440 Vac
Frequency	50 Hz
Cos φ	0.8
Model A.V.R.	HVR-30 (3ph. sensing)
Voltage regulation acc.	± 1,0 %
Sustained short circuit current	≥ 2,5 In (x10 sec.)
Transient dip (100% load)	< 10 %
Recovery time	< 0,3 sec
Efficiency at 100% load	92,3 % (400V - Cos φ 0,8)
Insulation	Class H
Connection - Terminals	Star - N°12
Electromagnetic compatibility (R.F.I. suppr.)	EN 55011
Waveform distortion - THD	< 3 %
Telephone interference - THF	< 2 %

REACTANCES (130 kVA - 400V)

Direct axis synchronuos - Xd	295 %
Direct axis transient - X'd	19 %
Subdirect axis transient - X''d	8,5 %
Quadrature axis synchronuos - Xq	195 %
Quadr. axis subtransient - X''q	/
Negative sequence - X2	/
Zero sequence - X0	/
TIME CONSTANTS	
Transient - T'd	0,023 sec
Subtransient - T''d	0,010 sec
Open circuit - T'do	0,298 sec
Armature - Ta	/
Short-circuit ratio Kcc	0.45
Grado di Protezione IP	IP 23
Cooling air flow	0.3 m³/sec.
Coupling Bearing	Direct SAE 3 -11 ½ - N°1

GENERAL SPECIFICATIONS

Fuel tank capacity	350 lt.
Running time (75% to PRP)	13,2 h
Starter battery	12 Vdc -100Ah / 800A CCA(EN)

IP protection degree	IP 44
Acoustic pressure LpA	72 dB(A) @ 7m
Performance class (ISO 8528)	G3

CONTROL PANEL

- Power switch
- Siren
- Emergency stop button
- Switch magnetermic
- Electronic differential relay
- Power terminal block
- Earth terminal (PE)
- Output sockets:
 - 1x 400V 125A 3P+N+T CEE IP67
 - 1x 400V 63A 3P+N+T CEE IP67
 - 1x 400V 32A 3P+N+T CEE IP67
 - 1x 400V 16A 3P+N+T CEE IP67
 - 1x 230V 16A 2P+T CEE IP67
 - 1x 230V 16A 2P+E SCHUKO IP67
- Magnetothermic switch (for 125A socket)
- Differential circuit breaker for 400V 63A socket
- Differential circuit breaker for 400V 32A socket
- Differential circuit breaker for 400V 16A socket
- 2x Differential circuit breaker for 230V 16A socket



INTELLITE4 AMF9 CONTROLLER CHARACTERISTICS	
Operating mode	<ul style="list-style-type: none"> • OFF - MAN - AUTO - TEST
Display - Pulsanti-LEDs	<ul style="list-style-type: none"> • Backlit display, LCD 132x64 pixels • Buttons / Buttons: START - STOP - RESET ALARMS / FAULT RESET • LEDs: Generator / GCB ON status - Grid status
Generator Measures	<ul style="list-style-type: none"> • Voltage : L1-L2 / L2-L3 / L3-L1 - N-L1/N-L2/N-L3 • Current : I1 - I2 - I3 • Frequency Hz • Powers : kVA - kW - kVAR (totali e per fase) • Energy : kWh - kVAh - kVARh • Cos φ (medium and per phase)
Engine Measures	<ul style="list-style-type: none"> • Water temperature • Oil pressure • Fuel level • Rpm meter • Battery voltage • Maintance • Hours meter • Starts number
Generator Protections	<ul style="list-style-type: none"> • Overload • Overcurrent • Short circuit • Over-Undervoltage • Over-Underfrequency • Voltage asymmetry • Unbalanced current • Phase sequence
Engine Protections	<ul style="list-style-type: none"> • Overspeed • High water temperature warning • Low oil pressure warning • Low fuel level warning • Over-Under battery voltage • Battery charge alternator failure • Start failure • Stop failure • Emergency stop • Low water level shutdown (option)

AMF functins (Automatic control panel only)	<ul style="list-style-type: none"> • Measure mains voltage : L1-L2 / L2-L3 / L3-L1 - N-L1/N-L2/N-L3 • Measure mains frequency • Three phase detection • Over-Under mains voltage • Over-Under mains frequency • Voltage asymmetry • Phase sequence • Dual mutual stand-by application
Features	<ul style="list-style-type: none"> • Event history, 150 stored events • 3 programmable test timers • Programming from panel or from PC • 3 selectable languages (other languages available) • Direct connection to engines with ECU (Stage V, Tier 4 Final) via Can Bus J1939 • External Start and Stop • Programmable inputs and outputs • Alternative configurations (50 / 60Hz) • IP 65 protection • Operating temperature: -20 ° C - + 70 ° C
Communication	<ul style="list-style-type: none"> • USB port • RS232- RS485 (optional) • Modbus RTU / TCP (optional) • GSM modem. Commands alarms, events via SMS (optional) • Internet connection with Ethernet (optional) • Online control and monitoring on web pages (embedded web server) (optional) • SNMP (optional) • GPS / 4G modem (optional) (geographical tracking via WebSupervisor) • Internal PLC support

WEIGHT - DIMENSIONS AND ACCESSORIES

GE 145 BSX



DRY WEIGHT MACHINE:
• 1780 Kg

Generating set pictured may include optional accessories.



DIMENSIONS DRAW

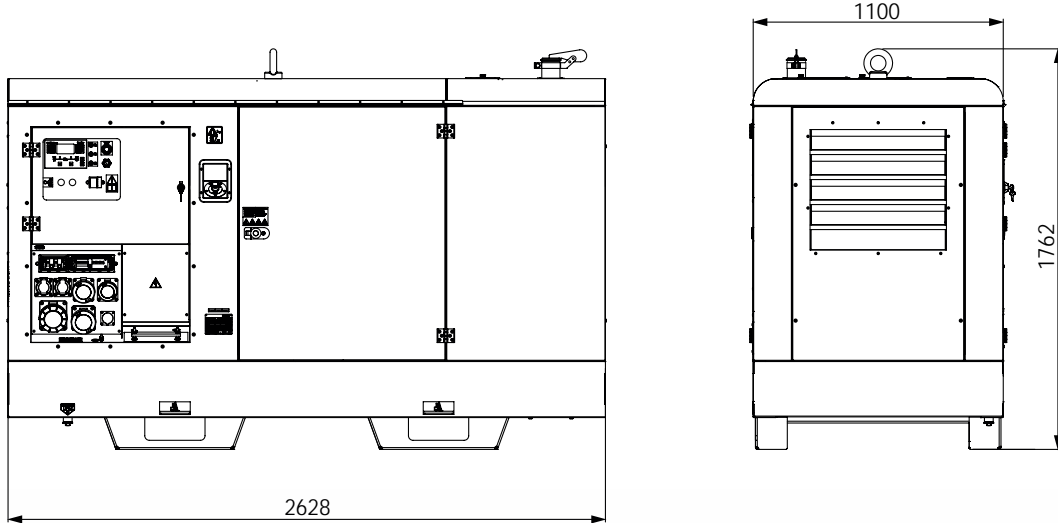

VERSIONS IN ADDITION TO THE STANDARD FEATURES

	HEATER	3WAY	PLUS	TOP
3-way valve		✓	✓	✓
Engine water heater	✓			✓
Spark extinguisher			✓	
Adjustment Volts from control panel				✓

OPTIONS ON REQUEST

- Internet plug-in module
- GPS/4G modem with antenna
- Plug-in module with double RS232 and RS485 port
- Report card for 15 alarms/statuses (configurable)
- Teleswitching panel (ATS) PAC-I PAC-I 170-M (12V - 250A)
- TCM35 remote control
- MT75 earthing

VERSIONS AVAILABLE

CH4W40G6R	STANDARD
CH4W40G6AR	HEATER
CH4W40G6HR	3WAY
CH4W40G6CHR	PLUS
CH4W40G6AHRU	TOP

GENERAL INFORMATION

COMPLIANCE GENERATING SETS WITH EC DIRECTIVES AND STANDARDS

- 2006/42 / EC (Machines Directive)
- 2014/35 / EU (Low Voltage Directive)
- 2014/30 / EU (EMC Directive)
- ISO 8528 (Reciprocating internal combustion engine driven alternating current generating sets)



ISO 9001:2008 - Cert. 0192

WARRANTY

All devices are covered by the manufacturer's warranty.

Non-contractual document. Specification subject to change without notice.

© MOSA - Viale Europa, 59 - 20047 Cusago (Milano) - Italy - phone +39-0290352.1 - fax + 39-0290390466 E-mail: export@mosa.it Web site: www.mosa.it

