

Use and Maintenance Manual

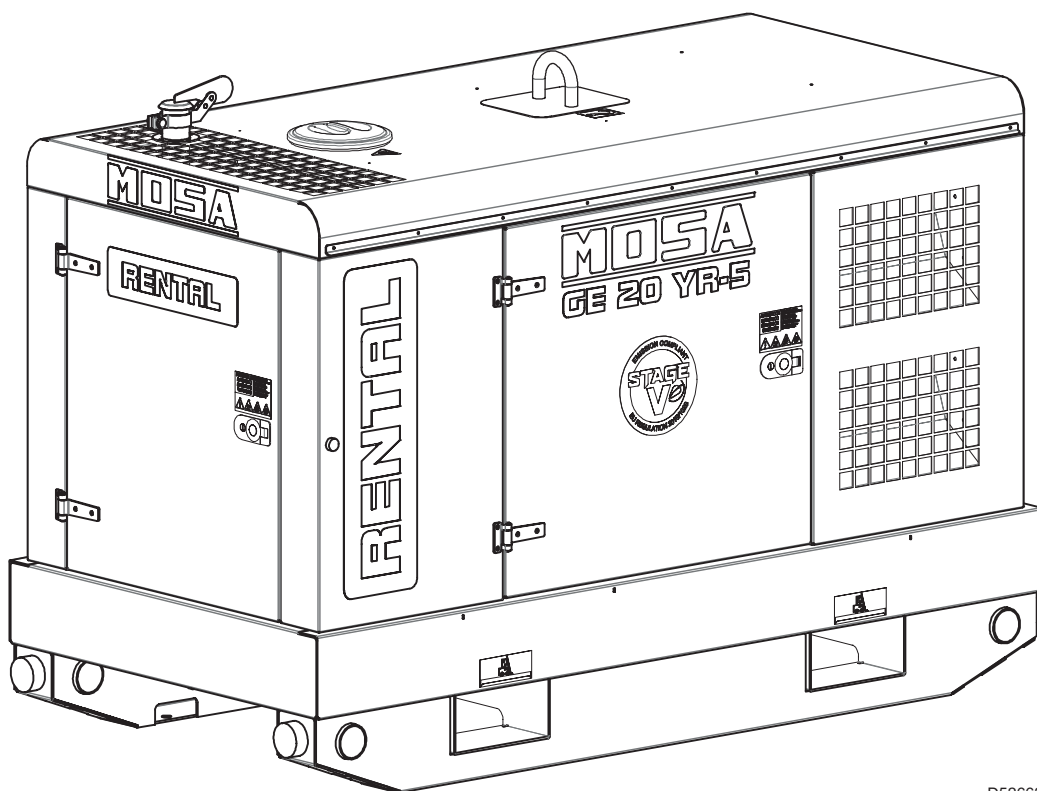

D5266260

Generating set GE 20 YR-5 - RENTAL



Original instructions

Contents

1.	Introduction.....	1
1.1	Foreword	1
1.2	Supplied documentation	2
1.3	Customer service.....	2
1.4	Spare parts	2
1.5	Declaration of conformity.....	2
1.6	Unauthorized changes.....	2
1.7	Allowed and non-allowed use.....	2
1.8	Identification data	3
1.9	Sound power level.....	4
2.	Safety.....	5
2.1	Safety information.....	5
2.2	Positioning of safety decal and information	6
	2.2.1 Decal explanation	7
2.3	General precautions	10
	2.3.1 Personal protective equipment.....	10
	2.3.2 Check the work area.....	10
2.4	Fire prevention.....	11
	2.4.1 Fire due to fuel, oil, coolant	11
	2.4.2 Fires caused by flammable material build-up	11
	2.4.3 Fire caused by electrical wiring	11
	2.4.4 Fire caused by piping	11
2.5	Handling precautions.....	12
	2.5.1 Lifting by chains or ropes.....	12
	2.5.2 Lifting by forklift.....	12
	2.5.3 Transport with towing carriages.....	13
2.6	Installation precautions.....	14
	2.6.1 Installation site precautions	14
	2.6.2 Precautions for open generating sets (SKID).....	14
	2.6.3 Precautions for electric connections.....	14
2.7	Precautions during operation.....	15
2.8	Precautions during fuel and engine oil filling	15
2.9	Maintenance precautions	16
2.10	Precautions for disposal of waste material	17
2.11	Disposing of the generating set.....	17
3.	Technical data	18
3.1	Machine dimensions.....	18
3.2	Technical data (mod. GE 20 YR-5).....	19
4.	Description.....	20
4.1	Main components	20
	4.1.1 External components.....	20
	4.1.2 Internal components.....	22
	4.1.3 Control panel components.....	24
	4.1.4 Electrical panel	27

4.2	Electrical protection	28
4.2.1	Main machine switch	28
4.2.2	Residual current circuit breaker	28
4.2.3	Circuit breaker	28
4.2.4	Residual current circuit breaker with overcurrent protection (RCBO).....	28
4.2.5	Ground differential relay	28
4.2.6	Insulation monitor	29
4.3	Optional fittings.....	31
4.3.1	3-way kit for fuel supply	31
4.3.2	Remote Start/Stop control	32
4.3.3	PAC-I mains/generator switchboard	33
5.	Installation.....	35
5.1	Fastening.....	35
5.2	Installation outdoors	35
5.3	Indoor installation	36
5.3.1	Supporting floor	37
5.3.2	Opening and ventilation of the room.....	37
5.4	Grounding.....	37
5.4.1	Grounding with residual current circuit breaker or earth leakage relay	37
5.4.2	Grounding with isolation monitor	38
5.5	Electrical connections.....	38
6.	Operation.....	39
6.1	Operating conditions.....	39
6.1.1	Power	39
6.1.2	Voltage.....	39
6.1.3	Frequency.....	39
6.2	Checks before start-up	41
6.3	Starting the generating set	41
6.4	Stopping the generating set.....	43
6.5	Emergency stop.....	43
7.	Maintenance.....	44
7.1	Refuelling.....	44
7.1.1	Fuel.....	44
7.1.2	Engine oil.....	45
7.1.3	Coolant	46
7.1.4	Checking and cleaning the engine air filter.....	47
7.2	Routine maintenance.....	48
7.3	Precautions for generating sets with automatic or remote start-up	49
7.4	Maintenance of generating sets with automatic intervention system	49
7.5	Storage.....	50
7.6	Disposal.....	50
8.	Overall dimensions for installation.....	51

1. Introduction

1.1 Foreword

This manual supplies the Operator and qualified and authorised Technicians with technical information on the GE 20 YR-5 "RENTAL" generating set (hereinafter also referred to as the "machine") produced by MOSA Div. of BCS S.p.A. (hereinafter also referred to as the "manufacturer").

In this manual, the Operator in charge and the qualified Technicians will find the indications for:

- Getting familiar with the safety measures and basic standards to be adopted, to prevent hazards and damage to people, to the generating set and to the environment.
- Getting to know the main components of the generating set and its operation.
- Performing the installation before start the machine.
- Performing the programmed routine maintenance.
- Getting to know any extraordinary maintenance operation.

This manual is an integral part of the generating set and must follow it in any changes of ownership, until the final dismantling.

The manual and all the publications attached to it must be kept with care, in an easily accessible place, known to the operator and to the qualified technicians authorized for maintenance; read the descriptions carefully before starting to work or carrying out the required adjustments or maintenance.

If the manual is lost, damaged or becomes illegible, request a copy to MOSA, indicating the model of the generating set, the serial number and the year of construction.

If the generating set is transferred, the transferor must deliver this manual to the new owner.

The generating set is subject to updates to improve its performance; this manual summarises the information regarding the current state of technology at the moment of the supply.

MOSA reserves the right to make improvements and modifications to parts and accessories of the generating set, without promptly updating this manual, except in exceptional cases of fundamental integrations concerning safe operation.



CAUTION

- **Improper use or maintenance can cause serious damage to people and shorten the "useful life" of the generating set.**
- **The Operator and the qualified Technicians must be familiar with all the indications given in this manual before using the generating set or carrying out maintenance operations on it.**
- **The procedures contained in this manual are intended to be applicable to generating sets only for permitted uses, and with all safety devices in function.**

If the generating set is used for purposes other than those indicated or in safety conditions other than those indicated, the Customer becomes directly responsible for any person possibly involved in accidents or injuries and for abnormal wear and tear of the machine.

1.2 Supplied documentation

The documentation supplied with the generating set includes this Use and Maintenance Manual and the main component manuals (e.g. engine).

1.3 Customer service

The Technical Assistance and Spare Parts Service are available to the Customers.

MOSA recommends that you contact the nearest authorised service centre for specialised intervention for all control and overhaul operations.

In order to obtain quick and effective responses, indicate the Model and Serial Number shown on the identification plate (see "1.8 Identification data").

1.4 Spare parts

Only original spare parts that guarantee functionality and durability must be used.

The use of non-original spare parts will void all warranty and Technical Support obligations.

1.5 Declaration of conformity

The manufacturer:

MOSA Div. of BCS S.p.A.

Viale Europa, 59 20047 Cusago (Milano) Italy

Declares that the machines:

GE 20 YR-5

Complies with the requirements of the following EC/EU Directives:

- Machine Directive 2006/42/EC
- Low Voltage Directive 2014/35/EU
- Electromagnetic Compatibility Directive 2014/30/EU
- Noise Emission Directive for machines intended to operate outdoors 2000/14/EC as amended by 2005/88/EC

and with the requirements of the following UK regulations:

- The Supply of Machinery (Safety) Regulations 2008/1597
- The Electrical Equipment (Safety) - Regulations 2016/1101
- Electromagnetic Compatibility - Regulations 2016/1091
- The Noise Emission in the Environment by Equipment for use Outdoors - Regulations 2001/1701

1.6 Unauthorized changes

No changes can be made to the machine without MOSA'S authorization.

Unauthorized changes void any form of warranty on the machine and any civil and/or criminal liability in case of accidents or injuries

1.7 Allowed and non-allowed use

This generating set is used to generate electrical current in accordance with the specifications of the declared electrical system.

Combined with a PAC-I MAINS/GENERATOR switchboard, it forms a complex for the supply of electricity within a few seconds from the sudden absence of the commercial electricity grid.

For the PAC-I MAINS/GENERATOR connection, see "4.3.3 PAC-I mains/generator switchboard".

1.8 Identification data

The data identifying the generating set are given on the data plate applied in the area indicated in the figure. They are necessary for spare parts requests and communications with the Customer Service Department.

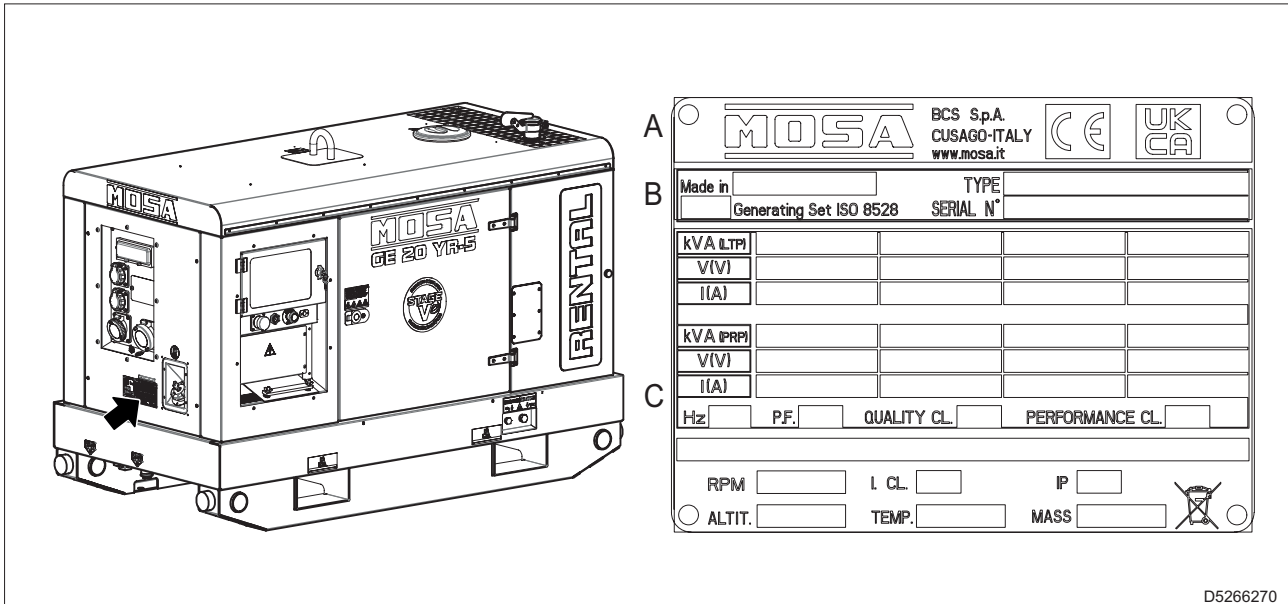

D5266270

- A - Manufacturer 's data
- B - Machine data
 - *Made In*: Country and year of manufacture
 - *TYPE*: Model
 - *SERIAL N°*: Serial number
 - *Generating Set ISO 8528*: Technical standard reference
- C - Machine technical data
 - KVA: LTP and PRP Power (kVA/kW)
 - V: Rated voltage
 - A: Rated current
 - Hz: Rated frequency
 - P.F.: Rated $\cos\phi$ (power factor)
 - QUALITY CL.: Quality class - Output
 - PERFORMANCE CL: Performance class - Output
 - Additional technical data:
 - RPM: Number of engine revolutions
 - I. CL.: Insulation class
 - IP: IP protection degree
 - ALTIT.: Rated altitude (above the sea level)
 - TEMP.: Rated ambient temperature
 - MASS: Dry weight (kg)

1.9 Sound power level

The sound power level of the generating set is given on the decal applied in the area indicated in the figure.

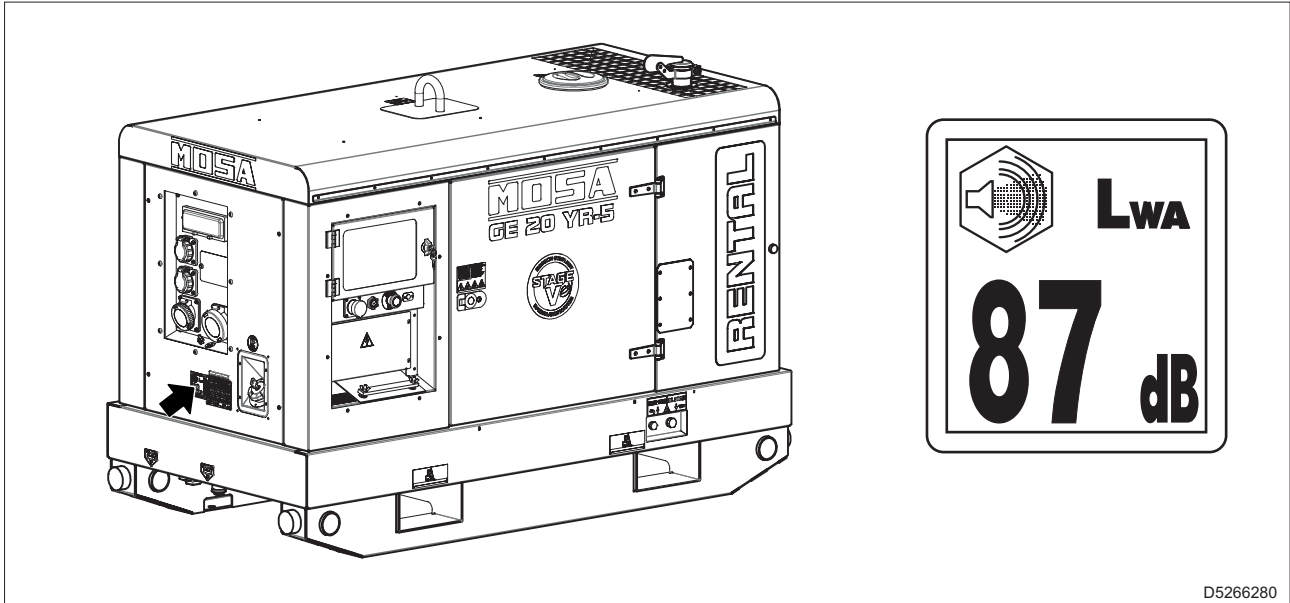

The value indicates the guaranteed sound power level in compliance with Directive 2000/14/EC.

- Sound power level (LWA) - Unit of measurement dB(A): represents the amount of acoustic energy emitted in the unit of time regardless of the distance of the measuring point.

2. Safety

2.1 Safety information

Always respect the warnings contained in this manual and present on the decal applied to the machine. This allows the machine to be used safely, avoiding damage to property and injury or death to people. The following words and symbols were used to identify important safety messages.

Symbol  identifies important safety messages on the machine, in the manual and elsewhere. When you see this symbol, follow the instructions in the safety messages.

DANGER

- This word indicates a situation of imminent risk that, if not avoided, could cause serious injury or even death to people and serious damage to property.

WARNING

- This word indicates a potential risk situation which, if not avoided, could result in serious injury or even death to people and serious damage to property.

CAUTION

- This word indicates a potential risk situation that, if not avoided, could cause minor or moderate injuries.
It can also be used to prevent dangerous operations that can cause damage to the machine.

The following terms are used to transmit the information to be followed to the user, to avoid damage to the machine.

Important

- If the precautions described are not observed, the machine could be damaged and its useful life reduced.

Note



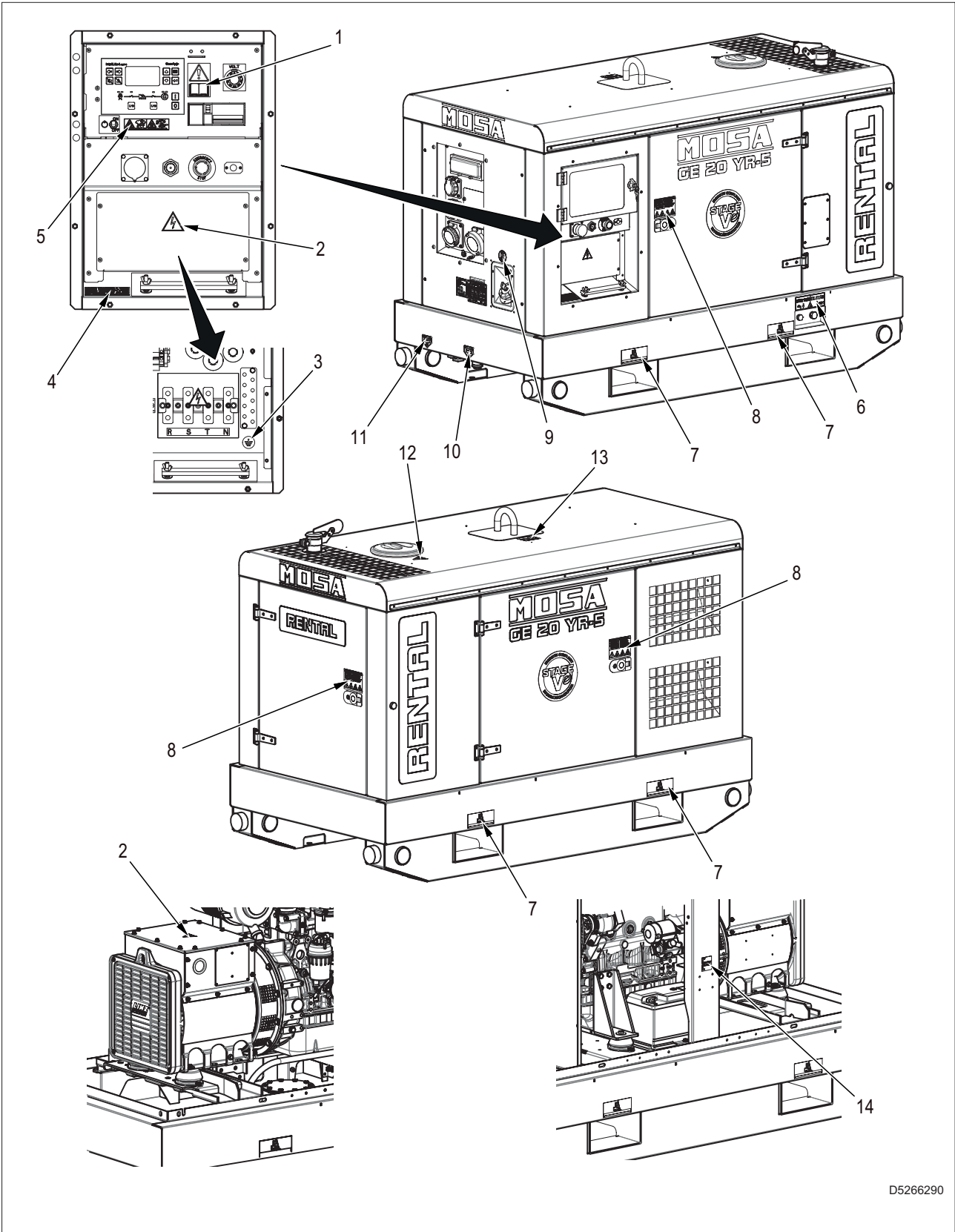

- This word is used to indicate further useful information.



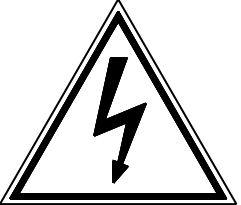

2.2 Positioning of safety decal and information



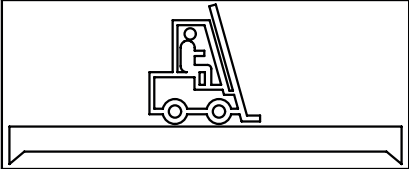
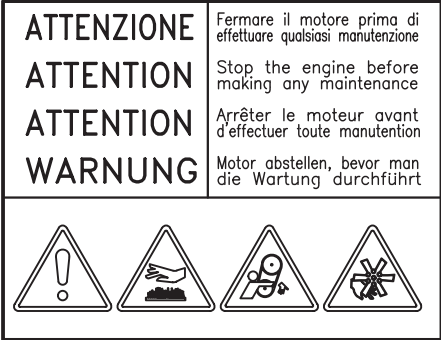

D5266290

2.2.1 Decal explanation

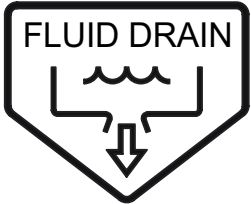
 <p>M734500253</p>	<p>Pos. 1 Consult the manual Read the contents of the manual carefully before using the machine or carrying out maintenance operations on it.</p>
 <p>M734500250</p>	<p>Pos. 2 - Electrical voltage hazard Stop the generating set before carrying out checks or maintenance.</p>
 <p>D5265970</p>	<p>Pos. 3 - Ground terminal Indicates the connection point of the machine to a grounding system.</p>
 <p>D5265700</p>	<p>Pos. 3 - Equipotential ground terminal For DGUV compliant generating sets, it indicates the point where all the machine's earthing points are connected.</p>
<div style="border: 1px solid black; padding: 5px; width: fit-content;"> <p>NEUTRO COLLEGATO A MASSA NEUTRO CONECTADO A MASA NEUTRAL BONDED TO FRAME NEUTRE RACCORDE AU BÂTI NULLEITER AUF MASSE NUL VERBODEN MET MASSA</p> </div> <p>D5264030</p>	<p>Pos. 4 - Neutral connected to earth. Indicates that the star centre of the generator (Neutral) is connected to earth.</p> <p> Important The absence of the decal on the machine indicates that the star centre of the generator (Neutral) is floating.</p>
<div style="border: 1px solid black; padding: 5px; width: fit-content;"> <p>Stromerzeuger Ausführung nach DGUV-I 203-032 B</p> </div>	<p>Pos. 4 - Compliance with the DGUV Regulation Indicates the compliance of the generating set with the DGUV regulation. The star centre of the generator (Neutral) is NOT connected to earth.</p>

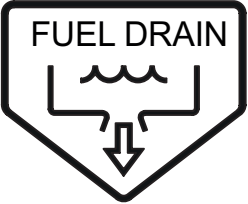
 <p>CARBON MONOXIDE (CO) DANGER STOP ENGINE WHEN FUELING</p> <p>D5263040</p>	<p>Pos. 5 - Fire and exhaust gas inhalation hazard Fuel is highly flammable. Turn the engine off and allow it to cool before fuelling. Engine carbon monoxide emissions are highly toxic and poisonous. Use the machine in outdoor and ventilated places.</p>
 <p>WATER DRAIN OIL DRAIN</p> <p>M849000250</p>	<p>Pos. 6 - Draining the coolant and the engine oil</p>
 <p>M840760202</p>	<p>Pos. 7 - Lifting points with forklift truck</p>
 <p>ATTENZIONE ATTENTION ATTENTION WARNUNG</p> <p>Fermare il motore prima di effettuare qualsiasi manutenzione Stop the engine before making any maintenance Arrêter le moteur avant d'effectuer toute manutention Motor abstellen, bevor man die Wartung durchführt</p> <p>MCP2T50G10250</p>	<p>Pos. 8 - Stop the engine before servicing To avoid burns due to contact with hot parts, before carrying out checks or servicing of the machine, stop the engine and wait until they have cooled sufficiently. To avoid serious injury, do not insert limbs near the rotating parts without stopping the engine.</p>
 <p>D5265680</p>	<p>Pos. 9 - Fuel filling neck</p>
 <p>FLUID DRAIN</p> <p>MCN4F40510250</p>	<p>Pos. 10 - Base liquids drainage</p>

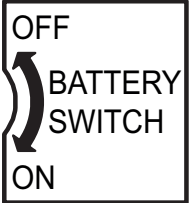
 <p>MCN1R50F10250</p>	<p>Pos. 11 - Fuel drainage</p>
 <p>M8B9700250</p>	<p>Pos. 12 - Coolant high temperature hazard Do not remove the cap when the engine is at the working temperature (high). Steam or the high temperature of the coolant leaking from the radiator can cause injury and/or burns to people.</p>
 <p>M209710202</p>	<p>Pos. 13 - Lifting hooking point</p>
 <p>MC1PN10430271</p>	<p>Pos. 14 - Battery disconnect switch</p>

2.3 General precautions

Any errors during use, checks or maintenance could cause the risk of injury, even serious

- Before performing the operations, read this manual and the decals applied to the machine and follow the warnings.
If you don't understand any part of the manual, ask your Safety Officer for explanations.
- The machine can only be used and repaired by trained and authorized personnel.
- Do not work if you feel unwell, have drunk alcohol or take medicines that impair your ability to work safely or repair the machine.
- Before starting the operations, check the machine. If anomalies are detected, do not operate on the machine before having completed the necessary repairs.
- Comply with the provisions and laws in force in the country in which you work.

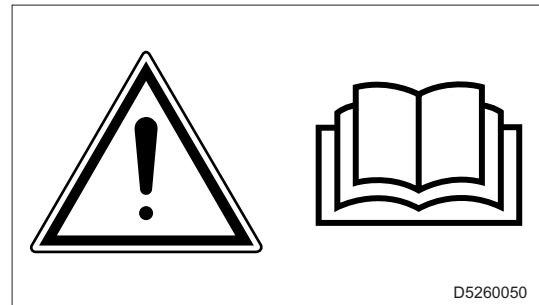

2.3.1 Personal protective equipment

- Do not wear clothes that are too loose or accessories, to prevent them from becoming entangled, causing personal injury.
- Always wear the personal protective equipment prescribed for the place where you work, such as a protective helmet, safety footwear, safety glasses, gloves and noise protection headphones.
- Before using personal protective equipment, check that it is in perfect condition.



2.3.2 Check the work area

- Ask the site safety manager for information on the regulations to be observed.
- Understand the signs and indications on site.
- Make sure that fire extinguishers and first aid kit are available on site and inquire about where they are located.
- Check that the area is clear of materials that may be hazardous during the operation of the generating set (such as flammable materials or liquids).
- Make sure that there are no unauthorized persons in the area.

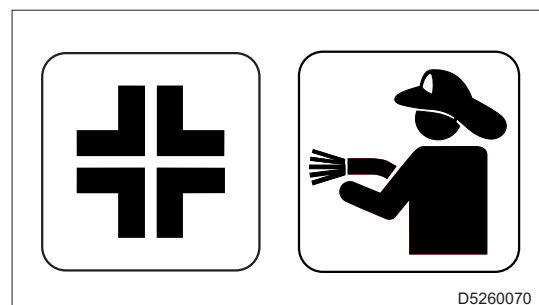

2.4 Fire prevention

2.4.1 Fire due to fuel, oil, coolant

- Avoid approaching any flame to flammable substances such as fuel, oil, coolant.
- Do not smoke or use open flames near flammable substances.
- Stop the generating set before refuelling.
- Make sure not to spill flammable substances on overheated surfaces or on parts of the electrical system.
- After refuelling, remove any spills and tighten all filling caps tightly.
- For safety in the workplace, store the cloths soaked in flammable materials in a container.
- Store oil and fuel in pre-established and well-ventilated locations and prohibit the entry of unauthorised personnel.
- When cleaning the generating set, do not use flammable substances such as diesel or gasoline.



2.4.2 Fires caused by flammable material build-up

- Remove dry leaves, chips, pieces of paper, carbon dust, or other flammable materials accumulated from the engine, exhaust manifold, muffler, battery, or inside the bottom guards.

2.4.3 Fire caused by electrical wiring

- Always keep the electrical wiring clean and tightened.
- Periodically check that there are no loose or damaged parts. Tighten loose wiring connectors or terminals.
- Repair or replace any damaged cables.

2.4.4 Fire caused by piping

- Periodically check that the hose clamps are firmly fixed.
- If loosened, they may vibrate during the operation of the generating set and cause leakage of liquids, causing fires and serious injuries, including fatalities.

2.5 Handling precautions

2.5.1 Lifting by chains or ropes

- Make sure that the handling area is clear of obstacles and people.
- Lift the generating set using only the lifting points provided and indicated by the decals.
- The operator carrying out the lifting work must be qualified to work with the crane.
- Always use lifting equipment adequately sized and controlled by authorized bodies.
- Keep the generating set in a horizontal position.
- Do not subject the generating set and the lifting equipment used to undulating or abrupt movements that transmit dynamic stresses to the structure.
- It is forbidden to fix on the frame of the generating set objects or accessories that modify the weight and centre of gravity of the machine and subject the lifting points to unexpected stresses.
- Do not lift the generating set at a height higher than that necessary for handling.
- Do not leave the generating set suspended for longer than necessary for handling.

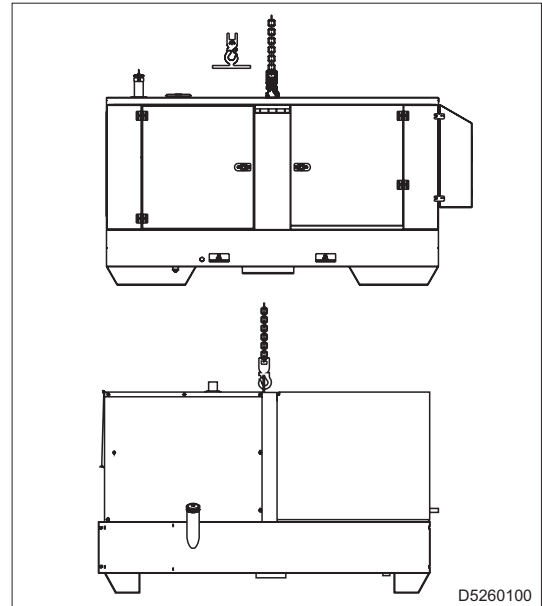

2.5.2 Lifting by forklift

- Insert the frame using the pockets indicated by the relative decals.
- Fork the generating set sideways to allow the forks to protrude from the opposite side.

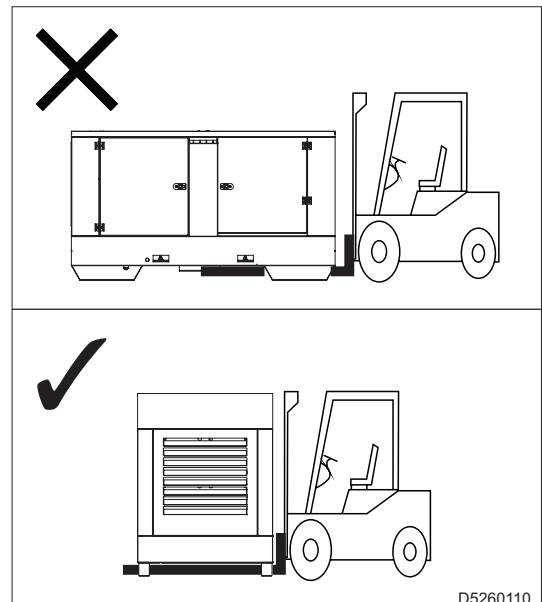

- Widen the forks as much as possible to distribute the weight evenly while keeping the generating set horizontal.

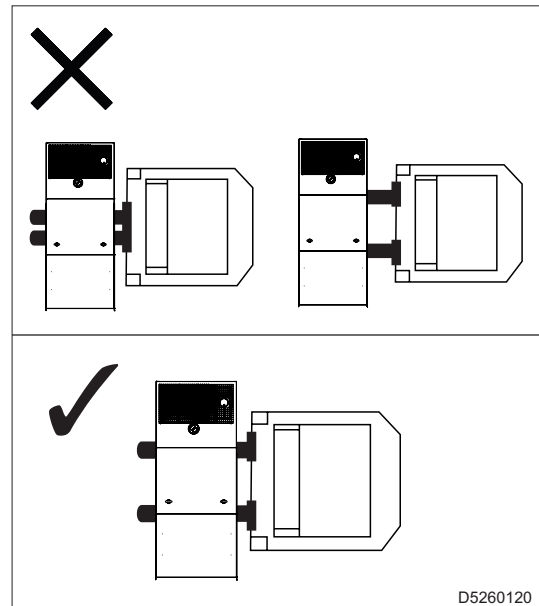

2.5.3 Transport with towing carriages

- Do not tow the machine manually or with tow vehicles without the intended towing carriage.
- Check the correct assembly of the machine to the drive device.
- Always check that the towing vehicle hook is suitable for towing the total mass (trolley+generating set).
- Do not tow the trolley if the coupling devices are worn out or damaged.
- Check the correct pressure of the carriage tires.
Do not replace the tyres with types other than the original ones.
- Check that the fixing bolts of the carriage wheels are present and pulled.
- Do not park the machine with the towing carriage on heavily tilted surfaces.
- In case of stops during transport, always apply the parking brake or lock the wheels with safety wedges.
- Do not tow the trolley on rough roads.

Transport with fast towing trolley

The fast towing trolley is approved for transport on public roads.

- Check the efficiency of the optical braking and signalling devices of the towing carriage.
- Do not exceed the maximum speed of 80 km/h with the towing carriage and comply with the regulations in force for road traffic.

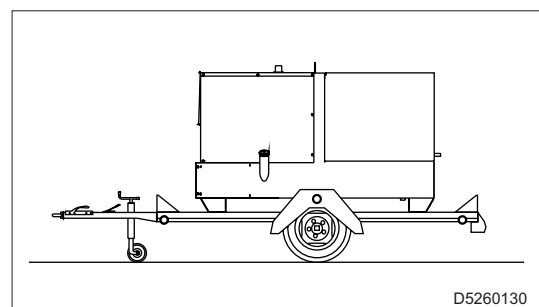

Transport with slow towing trolley

- Do not use the slow towing trolley on public roads. It can only be used in private and enclosed areas.
- The maximum speed allowed is 40 km/h on level surfaces (asphalt or concrete).
In any case, adjust the speed to the type of terrain.

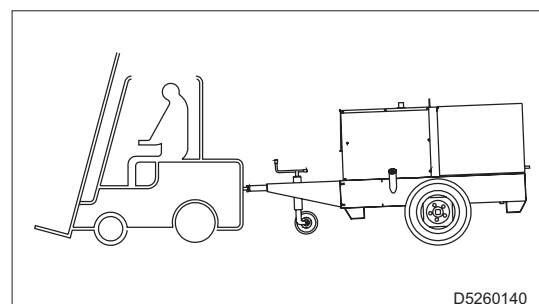

2.6 Installation precautions

2.6.1 Installation site precautions

- Do not install machines or equipment near heat sources, in areas at risk with explosion hazard or fire hazard.
Install the machine at a safe distance from fuel tanks, from flammable material (rags, paper, etc.), from chemicals.
Follow the instructions of the competent authorities.
- To limit potentially dangerous situations, isolate the area around the generating set, thus preventing any unauthorized personnel from getting close to it.
- Although the machines produced comply with the regulations on electromagnetic compatibility, do not install the unit near equipment influenced by the presence of magnetic fields.
- Make sure that the area immediately surrounding the machine is clean and free of debris.
- Always place the machine on a flat, solid surface that is not subject to failure in order to avoid tipping, slipping or falling during operation.
Avoid using the machine on land with a slope greater than 10°.
- The machine must always be positioned so that exhaust gases disperse into the air without being inhaled by people or animals.
The exhaust gases of an engine contain carbon monoxide: this substance is harmful to health and, in high concentration, can cause poisoning and death.
- If the machine is used indoors, the installation should be designed by specialized technicians and carried out in a workmanlike manner.
- The guard used to protect the generating set must not prevent the required normal cooling of the components.



2.6.2 Precautions for open generating sets (SKID)

- Open machines (SKIDS) must be installed on pitches protected against atmospheric agents such as rain, snow, high humidity and direct exposure to the sun.
If the alternator of the machine comes into contact with water or high humidity, especially during operation, the voltage supplied can rise beyond the limits, winding failures, electrical discharges towards the ground with damage to the machine, to the user systems and danger to people.
- Prevent the generating set from coming into contact with dust, especially of a saline nature.
If the radiator or the intake filters of the engine or the radiator are clogged with particles present in the air, there is the risk that the generating set will overheat and become damaged.
- Make sure that the suction grilles are not clogged with leaves, snow or other materials.

2.6.3 Precautions for electric connections

- Connect the machine to a grounding system according to the regulations in force at the place of installation.
- Use the ground terminal located on the front of the machine.
- Use appropriate electrical plugs at the machine output sockets and make sure that the electrical cables are in good condition.
- Do not use the machine with wet or damp hands and/or clothing.

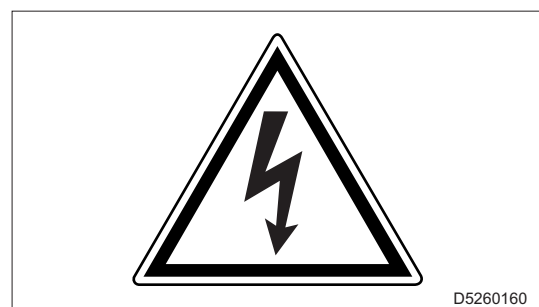

2.7 Precautions during operation

- Keep the doors closed during normal operation.
- Access to the internal parts of the generating set must only be carried out for maintenance purposes.
- Keep the area near the muffler free from objects such as rags, paper, cartons.
The high temperature of the muffler could cause the objects to burn and cause a fire.
- Immediately stop the machine in case of malfunctions.
Do not restart the machine without first identifying and solving the problem.
- Do not wrap or cover the generating set with cloths while it is running.
When the generating set is stopped, before covering it, make sure that the engine parts are cold
If the engine parts are still warm, there is a risk of damage to the machine and fire.
- Do not place objects or obstacles near the air suction and expulsion windows; a possible overheating of the generator could cause a fire.
- Exhaust gases must be conveyed so that they are not sucked out of the fans of the alternator or engine.
- The cover materials must be non-combustible; incandescent pins can escape from the exhaust pipe.

2.8 Precautions during fuel and engine oil filling

- Fuel and engine oil are flammable.
Refill with the engine off.
- Refuel only outdoors or in well-ventilated environments.
- Do not smoke or use naked flames during refuelling.
- Do not fuel with the engine running or hot.
- Clean and dry any leaks of engine oil and fuel before restarting the machine.
- After refuelling, fully tighten the tank caps.
- Do not fill the fuel tank completely to allow expansion of the fuel inside it.
- Do not exceed the MAX level line of the engine oil level dipstick.



2.9 Maintenance precautions

- Maintenance must be performed by qualified personnel.
- During maintenance, if unauthorized persons start the machine, there is a danger of serious personal injury or death. Do not allow unauthorized persons to approach the machine.
- Stop the machine and turn the battery disconnect switch to off.
- To avoid injury, do not perform maintenance with the engine running, if it is not necessary.
 - Rotating parts, such as the fan, are dangerous and can get entangled on body parts or a worn object. When performing maintenance, be careful to approach rotating parts.
 - Make sure not to drop or insert tools or other objects in the fan or other rotating parts. They can touch the rotating parts and be projected.
- Do not touch the engine, pipes and muffler during operation or immediately after shut-off. Allow the engine to cool before performing any operation.
- When discharging the engine oil, the engine must be hot. Engine oil may come into contact with the skin and cause burns.
- Do not remove the guards and safety devices. If it is necessary to remove them, after completing the maintenance, install the removed guards and restore the safety devices.
- Use work tools in good condition and suitable for the work to be performed. If you use a damaged or deformed tool or if you use a tool for a purpose other than its intended purpose, there is a danger of causing serious personal injury or death.
- Do not remove the radiator cap with the engine running or hot. The coolant may leak and cause serious burns.
- Do not operate the battery without using protective gloves. The battery liquid contains corrosive sulphuric acid.

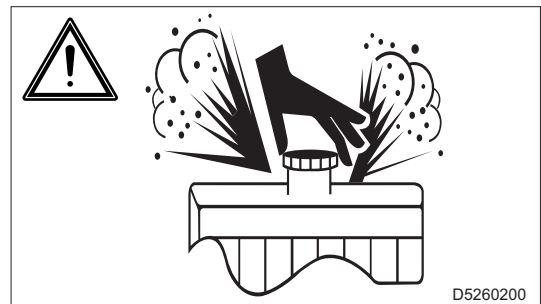
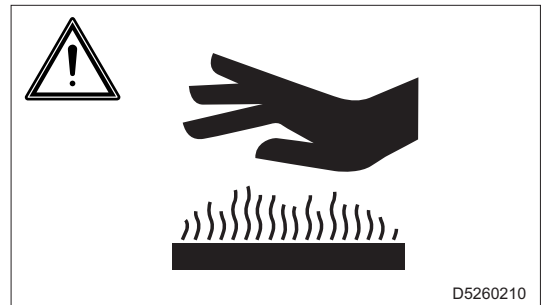

- Do not smoke, avoid open flames and sparks near the battery; exhaled vapours may cause the battery to explode.



2.10 Precautions for disposal of waste material

- Be sure to store the waste liquid in containers or tanks.
- Do not discharge the oil directly into the soil or sewage system, rivers, seas or lakes.
- When disposing of harmful waste such as oil, fuel, coolant, solvents, filters and batteries, follow current laws and regulations.
- Entrust the authorized companies with the disposal of rubber material, plastic and components that contain them (hoses, cables, wiring, etc.) in accordance with the applicable laws and regulations.
- For further information, visit <https://bcsgroup.it/it-it/sostenibilita/#etichettatura-ambientale> or scan the QR code.

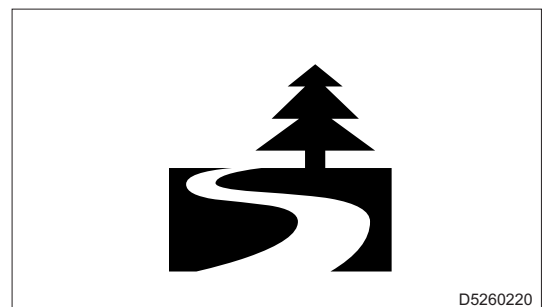

2.11 Disposing of the generating set

This generating set is classified as Electrical Equipment.

For disposal, comply with *Directive 2012/19/EU* on waste of electric and electronic equipment (WEEE).

The symbol affixed to the product or to the documentation states that, at the end of its useful life, the generating set must be disposed of separately.

Adequate separate collection helps avoid possible negative effects on the environment and health and promotes the reuse and/or recycling of the materials that make up the equipment.

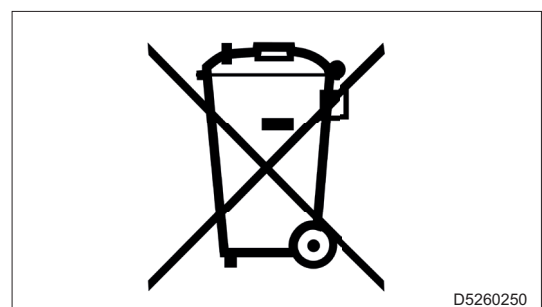

3. Technical data

3.1 Machine dimensions

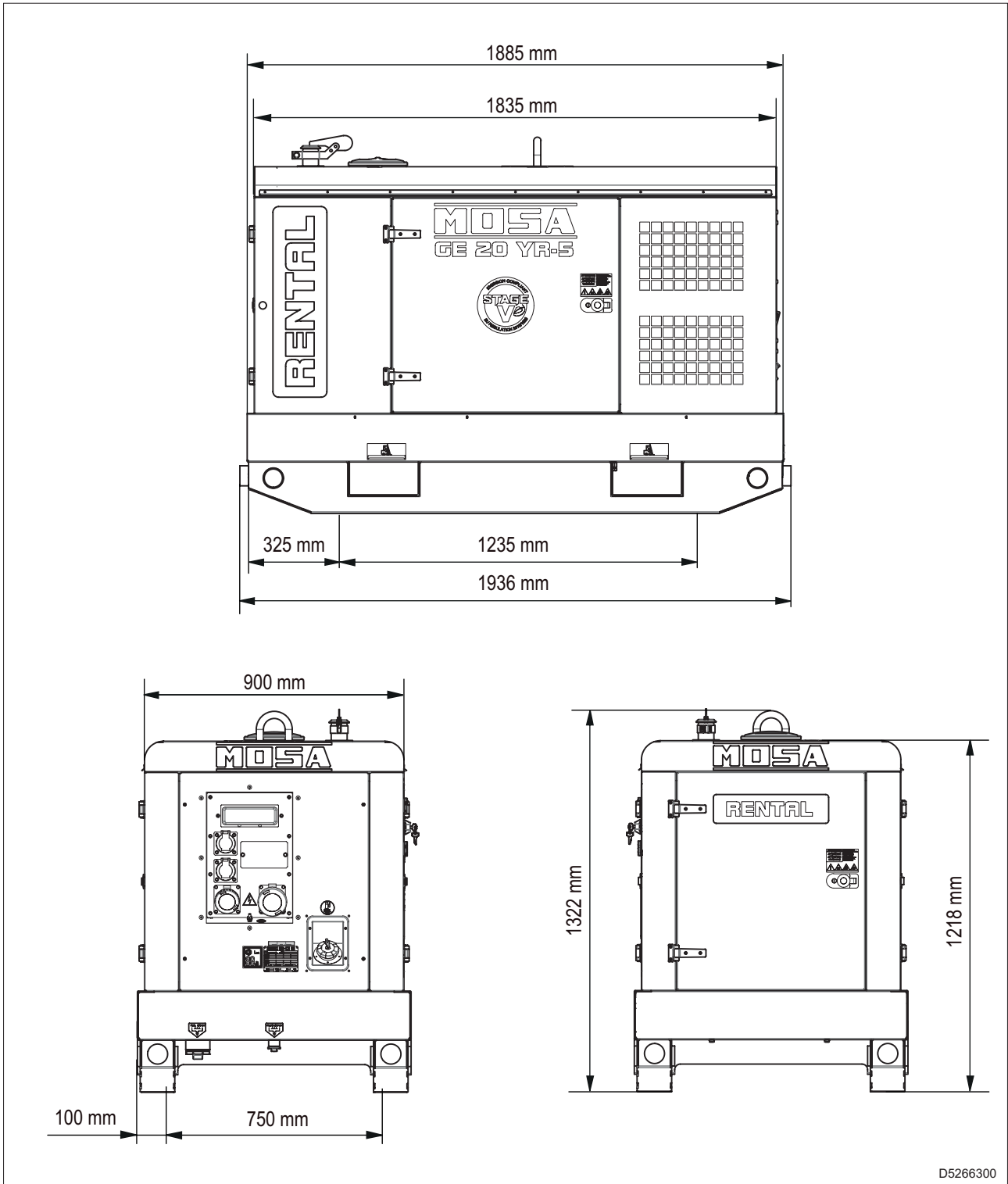

D5266300

3.2 Technical data (mod. GE 20 YR-5)

Rated power

Three-phase stand-by power ⁽¹⁾	20 kVA (16 kW) / 400V / 28.9A
Three-phase PRP power ⁽²⁾	18 kVA (14.4 kW) / 400V / 26A
Single-phase PRP power ⁽²⁾	7 kVA / kW / 230V / 30.4A
Frequency	50 Hz
Cosp	0.8

General specifications

Fuel tank capacity	100 ℓ
Autonomy (75% PRP)	29.5 h
Protection	IP 44
Maximum dimension on base (LxWxH)	1936 x 950 x 1329 mm
Weight (Dry)	840 kg
Measured sound power LWA	87 dB(A)
Measured sound level LpA	60 dB(A) at 7m

Engine

Brand/Model	YANMAR 4TNV88
Cooling system/type	4-stroke / water diesel
Cylinders / Displacement	4/2.19 l (2190 cm ³)
Net stand-by power ⁽¹⁾	18 kWm (25.4 hp)
Net PRP power ⁽²⁾	16.4 kWm (22.3 hp)
Speed	1500 rpm
Fuel consumption (75% PRP)	3.4 ℓ/h
Oil sump capacity (max.)	7.4 ℓ
Starter	electric

Alternator

Type	Synchronous three-phase-brush-less
Insulation class	H

Power declared according to ISO 8528-1 (temperature 25°C, relative humidity 30%, altitude 100 m above sea level).

⁽¹⁾ Stand-by = maximum power available for use at variable loads for a number of hours/year limited to 500h. Overloading is not allowed.

⁽²⁾ Prime power PRP = maximum power available for use at variable loads for an unlimited number of hours/year.

The average power withdrawable during a 24h period must not exceed 80% of the PRP.

An overload of 10% is allowed for one hour every 12 hours.

Approximately it is reduced: by 1% for every 100 m of altitude and by 2.5% for every 5°C above 25°C.

4. Description

The Generating Set is a machine that transforms mechanical energy, generated by an engine, into electrical energy through an alternator.

4.1 Main components

4.1.1 External components

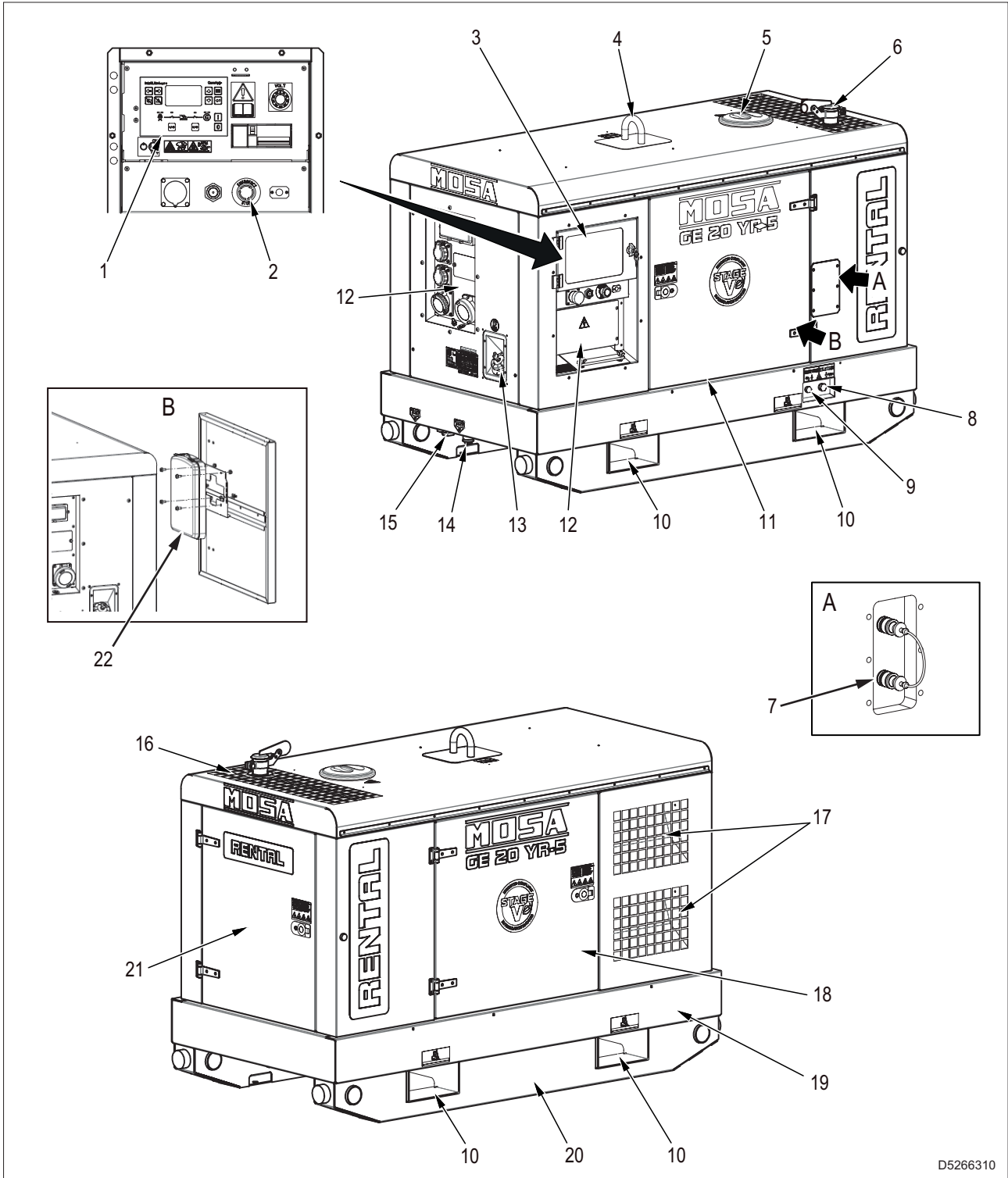

D5266310

Description

- 1 - Control panel
- 2 - Emergency button
- 3 - Control panel access door
- 4 - Lifting hook
- 5 - Radiator cap access door
- 6 - Rain cover for exhaust pipe
- 7 - Quick couplings for external fuel tank (optional)
- 8 - Oil drain plug
- 9 - Coolant drain plug
- 10 - Anti-tip side pockets for handling with forklift trucks
- 11 - Engine compartment access door
- 12 - Electrical distribution panel with three-phase and single-phase output sockets
- 13 - Fuel tank cap
- 14 - Fluid drain plug in the base
- 15 - Fuel drain plug in the tank
- 16 - Air outlet grid
- 17 - Cooling air inlet containers
- 18 - Battery compartment access door
- 19 - Liquid sealed base
- 20 - Dragging slide integrated in the base
- 21 - Radiator compartment access door
- 22 - Document holder

4.1.2 Internal components

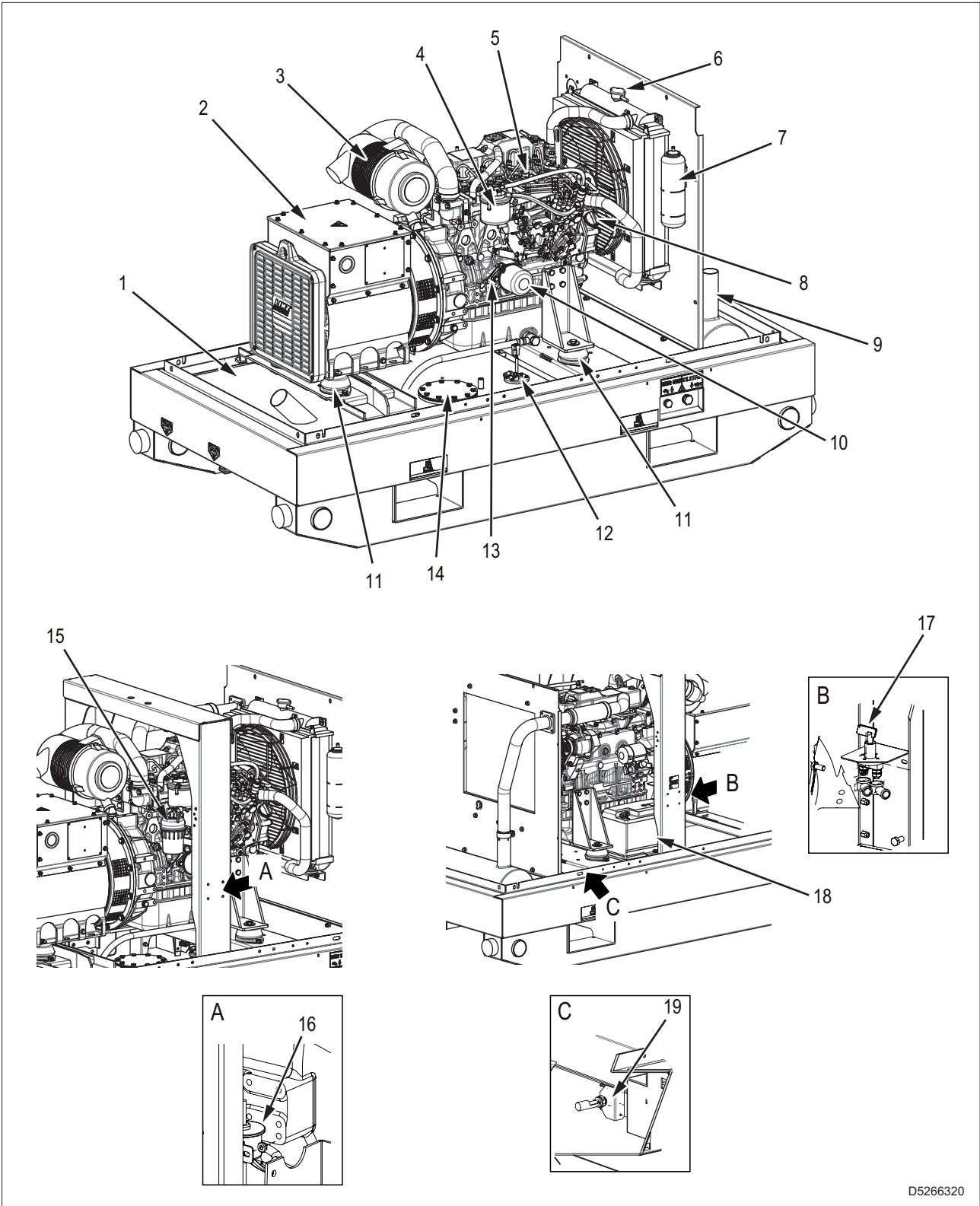

Description

- 1 - Fuel tank
- 2 - Alternator
- 3 - Engine air filter
- 4 - Fuel filter
- 5 - Engine
- 6 - Radiator cap
- 7 - Coolant expansion tank
- 8 - Oil filler plug
- 9 - Exhaust silencer
- 10 - Oil filter
- 11 - Vibration dampers
- 12 - Fuel level sensor
- 13 - Oil level dipstick
- 14 - Fuel tank cleaning access
- 15 - Fuel pre-filter
- 16 - Fuel supply pump
- 17 - Battery disconnect switch
- 18 - Battery
- 19 - Base liquid leakage sensor

4.1.3 Control panel components

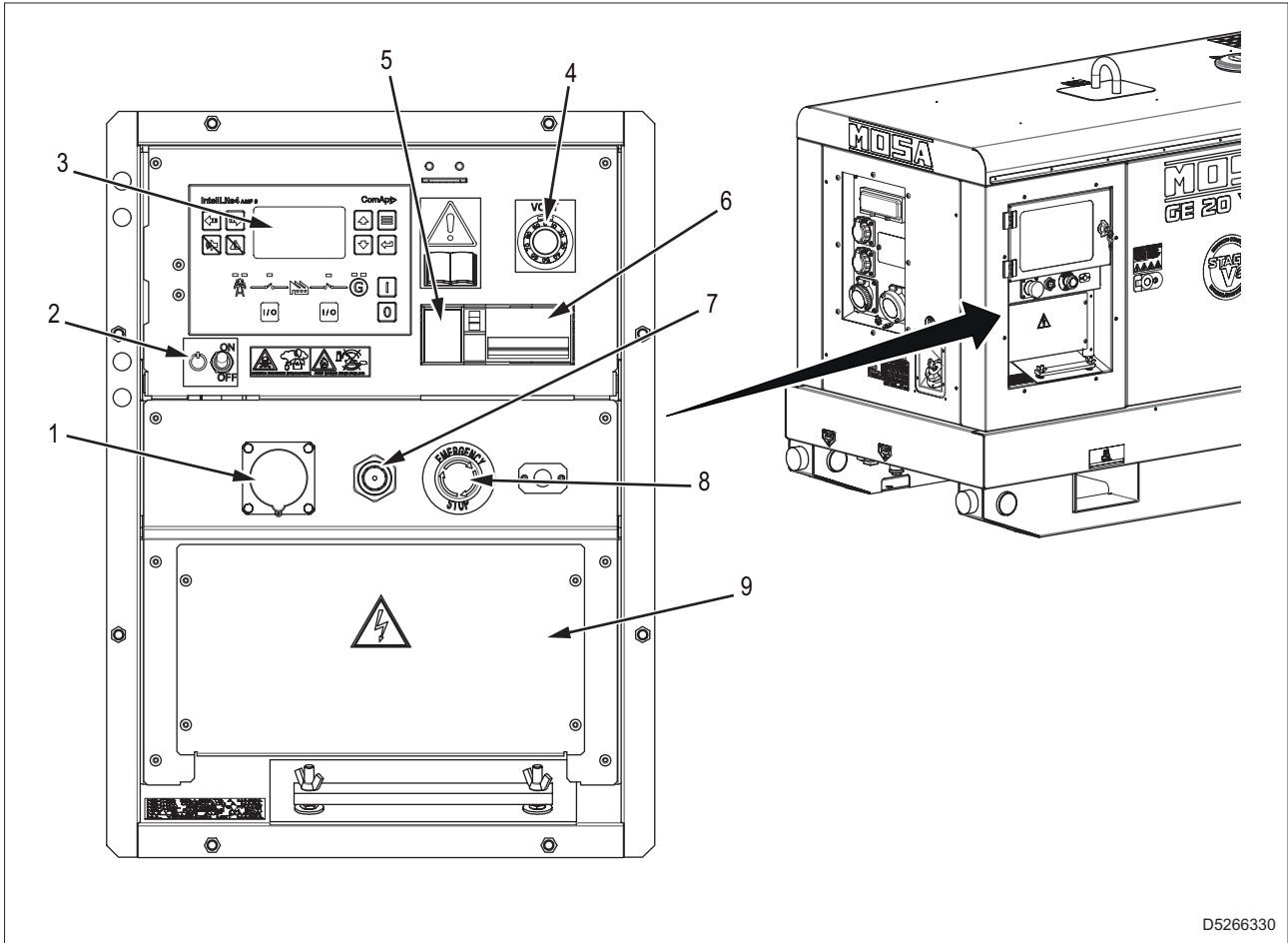

D5266330

- 1 - 16A 230V 2P+E CEE plug - Optional (Engine heater and battery charger power supply)
- 2 - Control panel power switch (ON-OFF)
- 3 - Command and control unit
- 4 - Generator voltage controller – Optional (+/- 10% Vn)
- 5 - Ground differential relay (EU panel)
- 5 - Isolation monitor (DGUV panel)
- 6 - Main machine switch
- 7 - Buzzer
- 8 - Emergency button
- 9 - Power terminal block

EU Standard

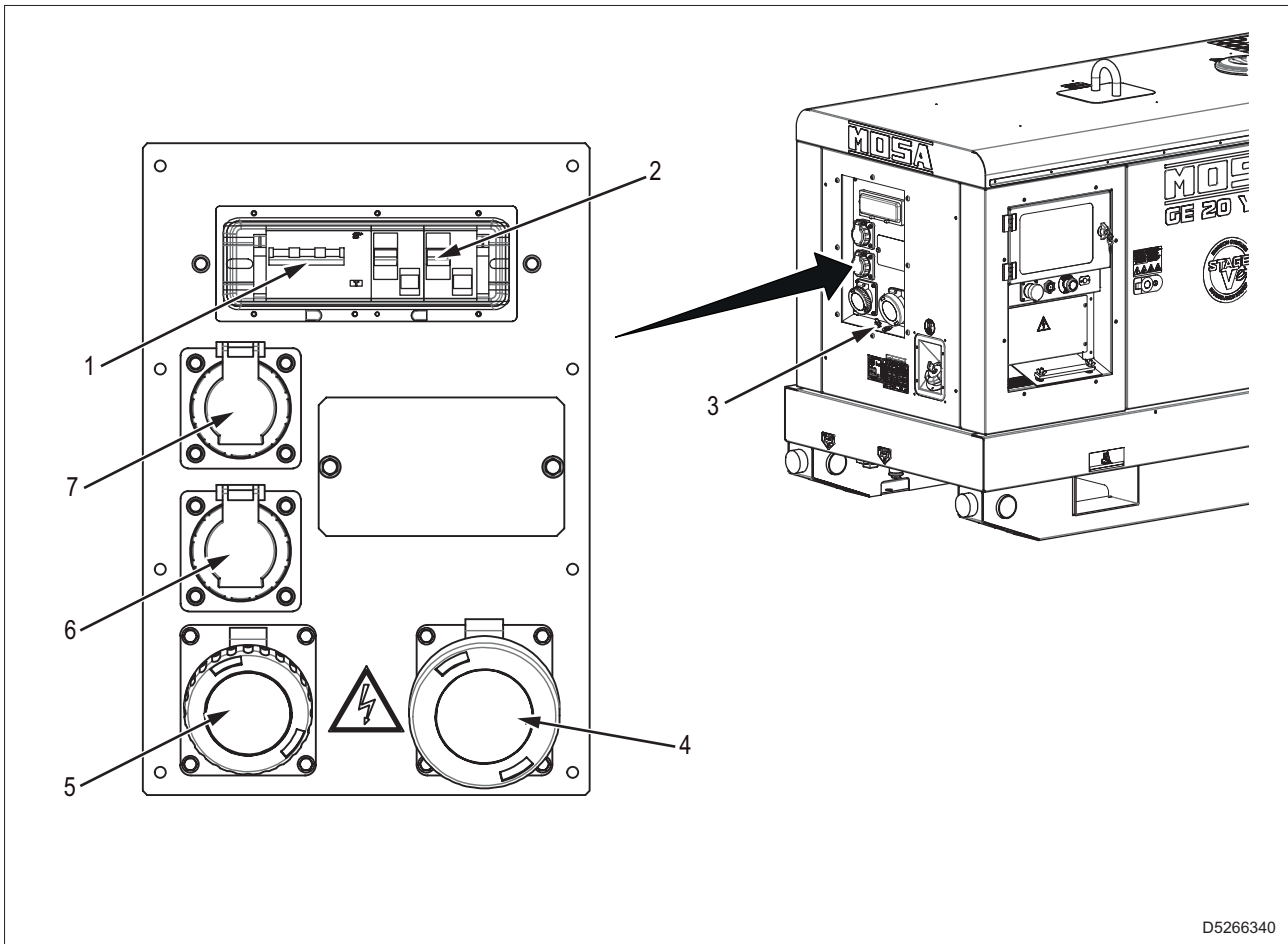

- 1 - Residual current circuit breaker with overcurrent protection (RCBO) (4P 16A - 30mA Type A) for three-phase 16A 400V socket
- 2 - Residual current circuit breaker with overcurrent protection (RCBO) (2P 16A - 30mA Type A) for single-phase 16A 230V socket
- 3 - PE ground terminal (EU panel)
- 3 - Equipotential ground terminal (DGUV panel)
- 4 - 32A 400V 3P+N+T CEE IP67 socket
- 5 - 16A 400V 3P+N+T CEE IP67 socket
- 6 - 16A 400V 2P+T SCHUKO IP68 socket
- 7 - 16A 230V 2P+T CEE IP67 socket

DGUV version

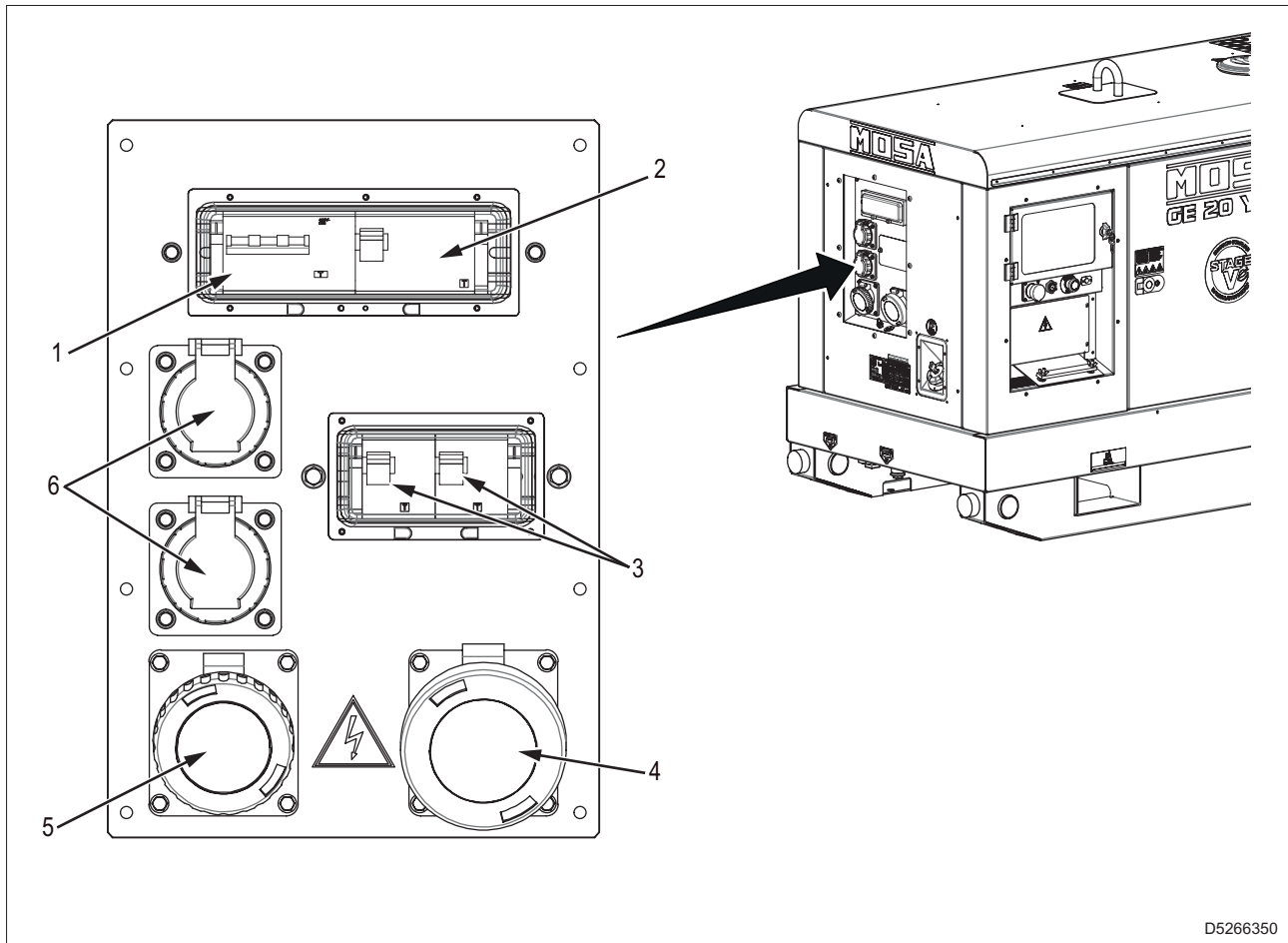

- 1 - Residual current circuit breaker with overcurrent protection (RCBO) (4P 16A - 30mA Type B) for three-phase 16A 400V socket
- 2 - Residual current circuit breaker (4P 40A - 30mA Type B) for three-phase 32A 400V socket
- 3 - Residual current circuit breaker with overcurrent protection (RCBO) (2P 16A - 30mA Type B) for SCHUKO 16A 230V sockets
- 3 - Equipotential ground terminal (DGUV panel)
- 4 - 32A 400V 3P+N+T CEE IP67 socket
- 5 - 16A 400V 3P+N+T CEE IP67 socket
- 6 - 16A 400V 2P+T SCHUKO IP68 socket

4.1.4 Electrical panel

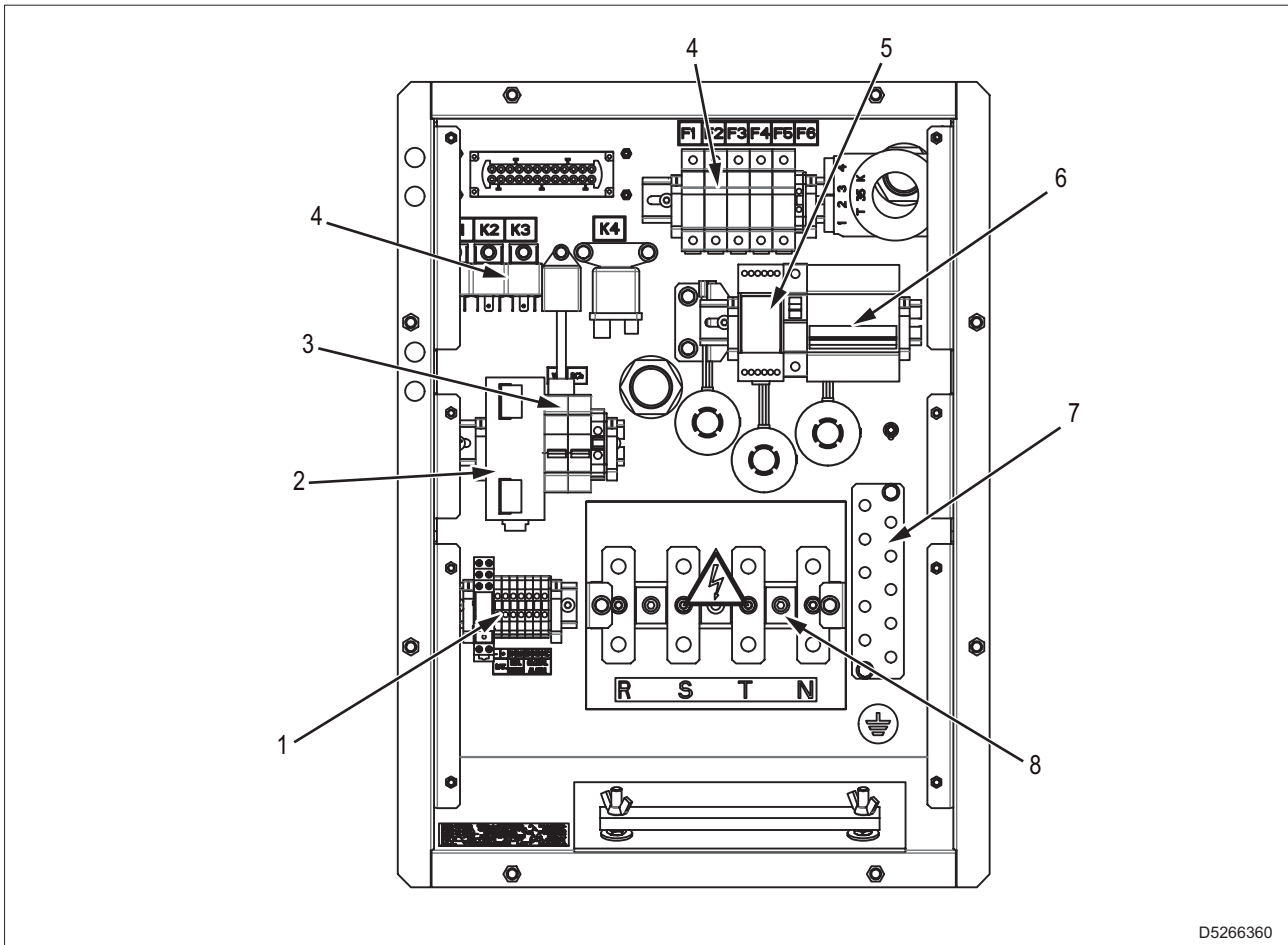

D5266360

- 1 - Auxiliary terminal block for the following connections:
 - Global alarm
 - Remote start and stop
 - Connection to PAC-I switchboard
- 2 - Battery charge
- 3 - Water heater and battery charge protection residual circuit breakers
- 4 - Auxiliaries (fuses and relays)
- 5 - Ground differential relay (EU panel)
- 5 - Isolation monitor (DGUV panel)
- 6 - Main machine switch
- 7 - Ground cable collector
- 8 - Power terminal block

4.2 Electrical protection

4.2.1 Main machine switch

The generating set is protected against short circuits and overloads by a circuit breaker (1) located upstream of the system.

Overload protection tripping is not instantaneous; it follows an overcurrent/time characteristic. The greater the overcurrent, the shorter the tripping time.

The rated tripping current refers to an operating temperature of 30°C. Each variation of 10°C corresponds approximately to a variation of 5% on the rated current value.

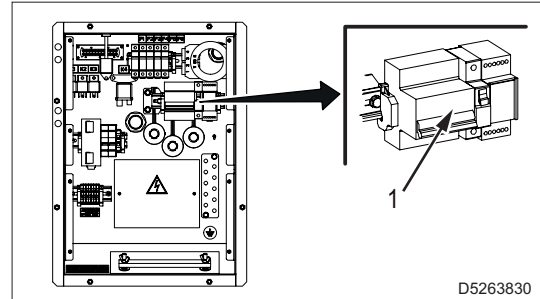

4.2.2 Residual current circuit breaker

The residual current circuit breaker guarantees protection against indirect contacts due to ground fault currents.

When the switch detects a fault current greater than the rated one, it opens interrupting the electric circuit connected.

The residual current circuit breakers differ according to their characteristics: tripping differential current, maximum rated current, type of differential correction detected.

4.2.3 Circuit breaker

The circuit breaker provides electrical protection against the short circuit and overcurrents.

In the electrical panel there are several circuit breakers (one for each output socket), allowing protection of the equipment connected to the sockets on the machine.

Overload protection tripping is not instantaneous; it follows an overcurrent/time characteristic. The greater the overcurrent, the shorter the tripping time.

The rated tripping current refers to an operating temperature of 30°C.

Each variation of 10°C corresponds approximately to a variation of 5% on the rated current value.

4.2.4 Residual current circuit breaker with overcurrent protection (RCBO)

The residual current circuit breaker with overcurrent protection (RCBO) performs both electrical protection functions against short circuits and overcurrents and against indirect contacts due to ground fault currents.

In the electrical panel there are several residual current circuit breakers with overcurrent protection (RCBO), one for each output socket, this allows to individually protect the equipment connected to the sockets.

The residual current circuit breakers with overcurrent protection (RCBO) differ according to their characteristics: tripping thermal current, magnetic tripping curve, breaking power, tripping differential current, type of differential correction detected.

4.2.5 Ground differential relay

Important

- Differential relay calibration changes must only be performed by qualified personnel. If necessary, contact Technical Support.

The ground differential relay allows you to choose the value of the tripping current in order to keep the values of the contact voltages below the limits set by electrical safety regulations.

These adjustments allow to operate a selective intervention based on the current, and (above all) time.

The relay is the ideal solution to be combined with the main switch of the panel when downstream there are several differential circuit breakers to protect the different output sockets.

- 1 - Ground fault current adjustment potentiometer
- 2 - Intervention time adjustment potentiometer
- 3 - Multifunction led for internal electronics fault report/internal temperature out of range / potentiometer t(SES) not centred correctly
- 4 - Power supply presence signal led
- 5 - Differential relay tripped signal led
- 6 - Tool set-up microswitches
- 7 - Test button
- 8 - Manual reset button

DER3/ 0D model factory settings

- Microswitches
- Output relay: N.De (Normally de-energized)
- Fault current adjustment: $I\Delta$: x 0.1
- Intervention time adjustment: t : x 1
- Reset: Man. (manual)
- Potentiometers
 $I\Delta$ (A) : 0.3 ÷ 0.5 (30mA ÷ 50mA)
 T(sec) : INST (Instant)

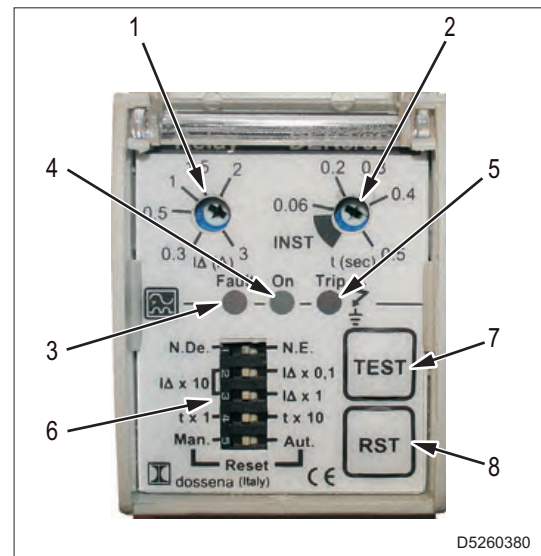

The differential relay has 2 tests, 1 of which is carried out automatically by the instrument:

- Manual test (test button).
- Automatic test of toroid-relay connection and release reel relay.

The differential relay can operate correctly even in the presence of harmonic distortion or with very disturbed signals.

If the internal temperature exceeds the operating threshold, the Fault led (3) flashes.

The interruption of operation due to a failure of the torus (breakage of the connecting wire) or a fault of part of the internal circuits, leads to the automatic intervention of the protection.

4.2.6 Insulation monitor

Important

- Isolation monitor calibration changes must only be performed by qualified personnel. If necessary, contact Technical Support.

The isolation monitor is a device that continuously controls the ground insulation of the electrical circuit.

When the device detects a resistance value (isolation) lower than the set value, it intervenes by signalling the fault and opening the main machine switch.

- 1 - Alarm threshold adjustment
- 2 - Dip-switch
- 3 - Pre-alarm indication led
- 4 - Power supply presence indication led
- 5 - Alarm indication led
- 6 - Test button
- 7 - Reset button
- 8 - Pre-alarm threshold adjustment

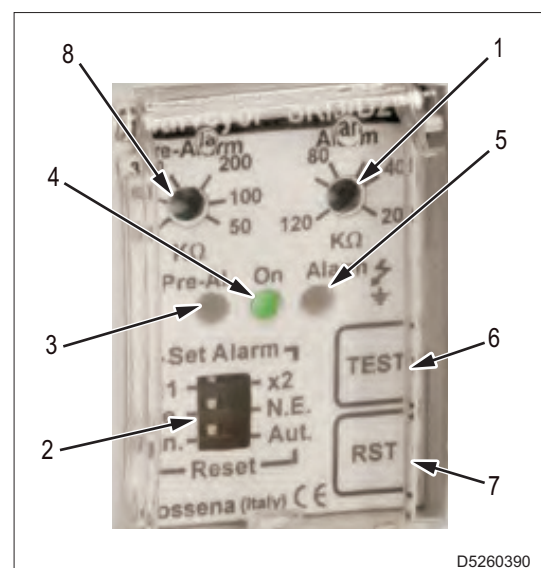

SRI3/ D2 operation

- ON indicator (4) indicates that the equipment is powered.
- Pressing the test button (6) for at least 5 seconds, turns on the Alarm (5) and Pre-alarm (3) LEDs.
- When the button (6) is released, the Pre-alarm led (3) turns off and the Alarm led (5) remains ON. Press the test button (6) again to turn off the Alarm led (5).
- If the isolation resistance drops below the set pre-alarm value, the Pre-alarm led (3) lights up and the contact of the Pre-alarm relay switches.
- If the isolation resistance drops further below the alarm value threshold, the Alarm led (5) turns on, along with the contact of the Alarm switch relay.
- After checking the system and removing the cause of the problem, reset the circuit by pressing the reset button (7).

SRI3/ D2 model factory settings

- Microswitches
- Resistive value multiplier: x 1
- Output relay: N.De (Normally de-energized)
- Reset: Man. (manual)
- Potentiometers
- Alarm: 40 k Ω
- Pre-Al. : 100 k Ω

4.3 Optional fittings

4.3.1 3-way kit for fuel supply

The 3-way kit allows you to supply the engine of the generating set from the fuel tank of the machine or from an external tank of greater capacity to increase the operating range.

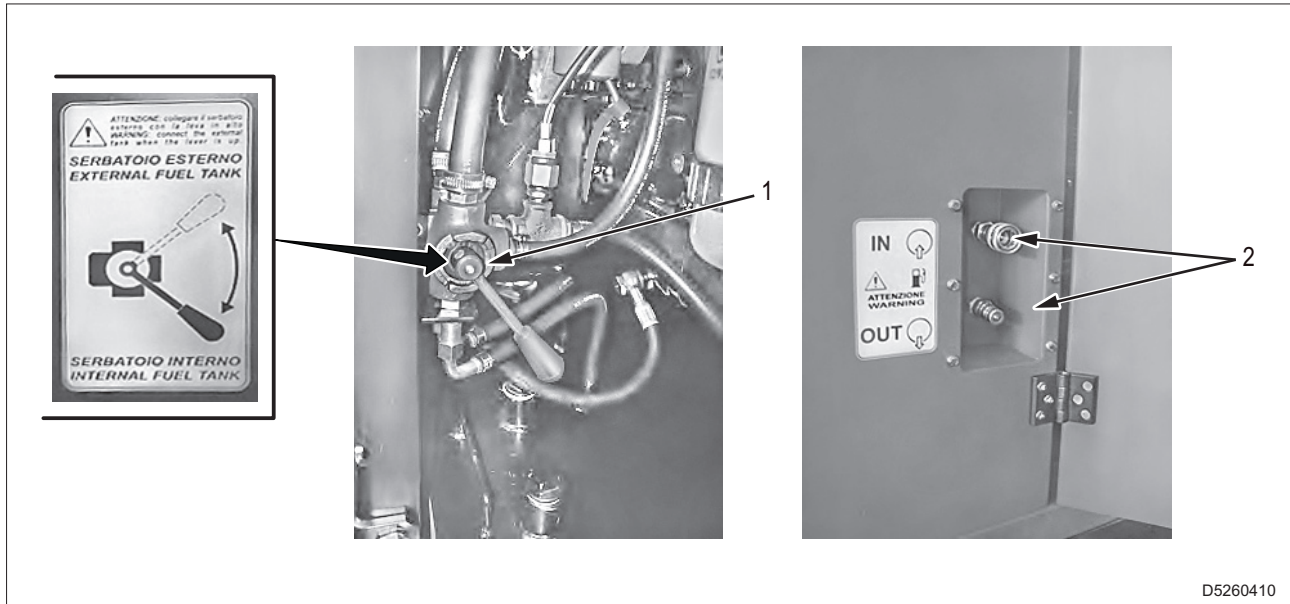

D5260410

It consists mainly of two parts:

- Three way valve (1) for tank selection.
- External quick hydraulic type couplings (2), for connecting the pipes from the external tank.

Fuel supply to the engine is always via the engine feed pump.

If using an external tank, comply with the following instructions:

- Place the external tank at the same level as the generating set.
- Use connecting pipes with a minimum diameter of 15 mm and a maximum length of 5m.

On the return pipe, there is a sensor that protects the engine in case of overpressure due to an incorrect position of the three way valve (1).

The protection tripping does not allow the engine to start or, if the engine is running, it stops it immediately.

The intervention is specifically indicated on the control panel.

The hydraulic type quick couplings (2) are 3/8" GAS.

The respective connections are supplied with the system.

If not connected, cover the quick couplings with the caps, to protect them from dust or dirt.

4.3.2 Remote Start/Stop control

Pairing the TCM 35 with the generating set allows it to be started and stopped by remote.

- 1 - Connect the cable (1) of the TCM 35 remote control to the auxiliary terminal block (2) located inside the electrical panel.
- 2 - Connect the cable (1) of the TCM 35 remote control to the terminals marked 'BK - 26 - REM. START'.

Note

- The connection of the cables to terminals BK and 26 is irrelevant.

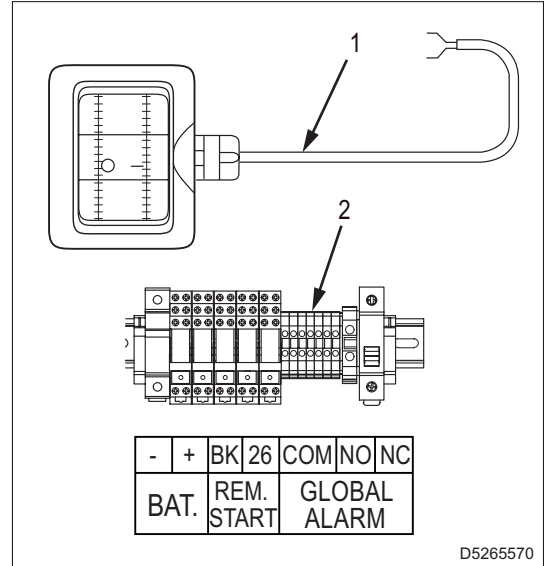

- 3 - Switch the command and control unit (3) of the generator to AUTO (automatic) mode.
- 4 - Set the switch (4) of the remote control to ON (I) to launch the generating set start sequence.

Important

- The remote control switch (4) must be left in the ON position to keep the generating set running.

- 5 - To launch the generating set stop sequence, set the remote control switch to OFF (0).
The engine stops at the end of the cooling cycle.

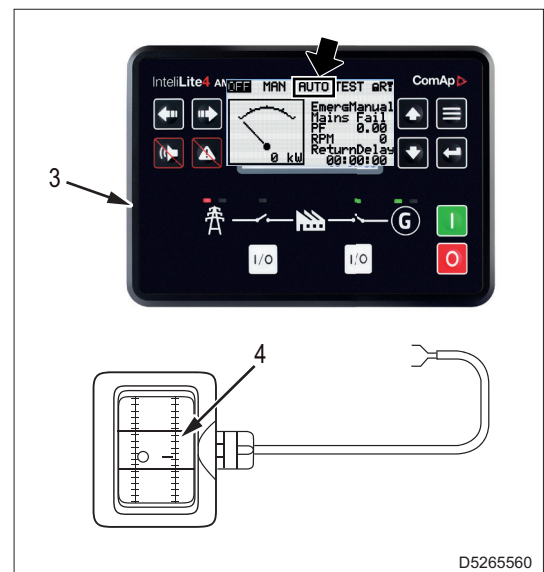

4.3.3 PAC-I mains/generator switchboard

Non-automatic versions



CAUTION

- Make the connections under safe conditions.
- The installation of the PAC-I switchboard and all connections between the board and the commercial electricity grid (MAINS), the system to be powered (LOAD) and the generating set (GENERATOR) must be carried out by a qualified electrician and in accordance with the regulations in force in the place of installation.

The generating set with control panel and electrical panel, combined with a PAC-I mains/generator switchboard, forms a unit for the supply of electricity within a few seconds from the failure of the commercial electricity grid.

Note

General operating information is provided below.

For details on installation, command, control and signalling, see the switchboard manual.

- 1 - To prevent sudden start-up, set the command and control unit (1) of the generating set to OFF and press the RE-SET key (2) on the command and control unit of the PAC-I switchboard.

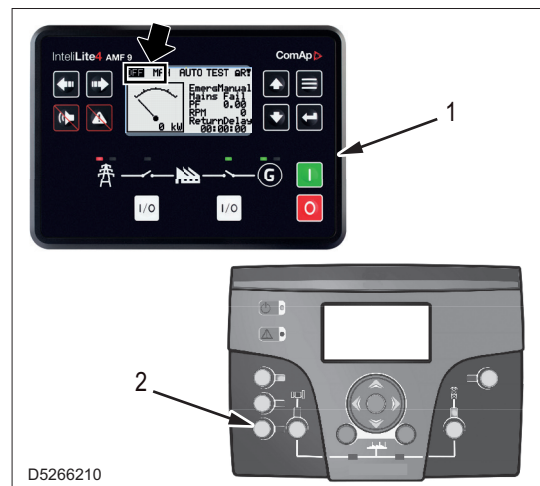

- 2 - Connect the cable (4) from the PAC-I switchboard to the auxiliary terminal block (3) inside the electrical panel, as shown in the wiring diagram.

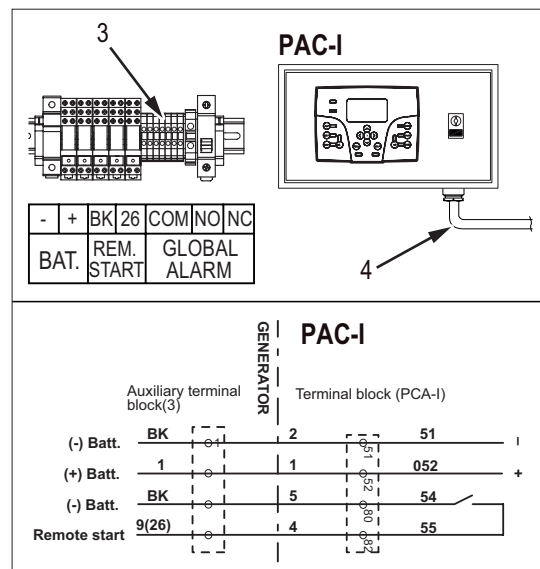

Description

- 3 - Follow the steps below for first start-up.
- Check that the main machine switch is closed (insertion lever upwards).
 - Set the command and control unit (1) to AUT (automatic) mode.
 - Press the MAN key on the command and control unit of the PAC-I switchboard, check for the absence of danger and press the KG key to start the generating set.
 - Check the values shown on both displays of the command and control units and the proper working order of the generating set.
 - Press the KR key to stop the generating set.
- 4 - Press the AUT key to switch to AUTO (automatic) mode and enable emergency operation.

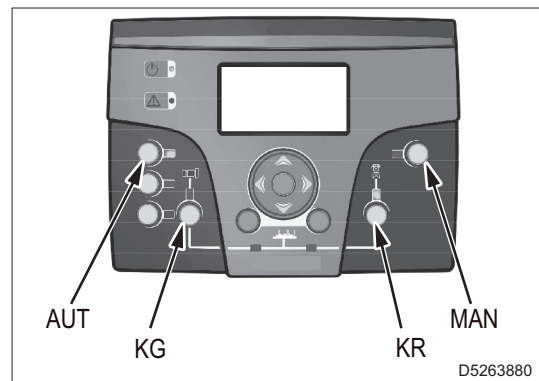
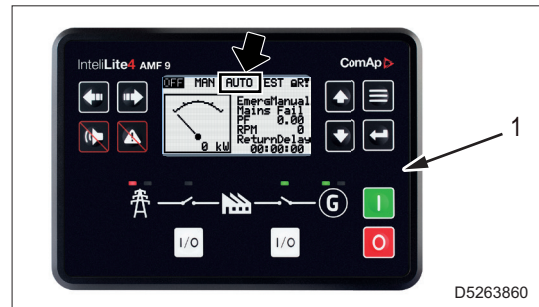

The different stages of emergency system management are split between the 2 control units.

Stage	Control unit
<ul style="list-style-type: none"> • No MAINS or MAINS out of limits detection 	PAC-I switchboard control unit (sends the start command to the control unit of the generating set)
<ul style="list-style-type: none"> • Engine start-up 	Generating set control unit
<ul style="list-style-type: none"> • GENERATING SET side switch closing command (The system is powered by the generating set - after the engine has warmed up and after checking that the generating set parameters are within the limits) 	PAC-I switchboard control unit
<ul style="list-style-type: none"> • MAINS back within limits detection. 	PAC-I switchboard control unit
<ul style="list-style-type: none"> • GENERATING SET side switch opening control and MAINS side switch closing control. 	PAC-I switchboard control unit (sends the stop command to the control unit of the generating set)
<ul style="list-style-type: none"> • Engine shutdown (after cooling period) 	Generator control unit.

5. Installation



WARNING

- Before proceeding with the installation, carefully read section “2. Safety” - “2.6 Installation precautions” and “2.7 Precautions during operation”.
- The installation and the electrical connection described in this chapter are indicative. For these operations, it is necessary to contact Specialized Technicians who must issue the necessary certifications.



Important

- For information on the overall dimensions for installation, see chapter “8. Overall dimensions for installation”.

5.1 Fastening

- Fix the generating set on rigid pitches, isolated against vibrations coming from other structures and with a mass equal to at least three times the mass of the generating set. This guarantees an adequate absorption of the vibrations produced by the machine.
- Do not place the generating set on terraces or raised floors that have not been adequately sized and verified beforehand.

5.2 Installation outdoors



WARNING

- If the outdoor installation is temporary, correctly place the generating set on the ground. This prevents vibrations on the frame during operation from causing the generating set to move, in particular when the electrical load is on.

Example of installation with shelter

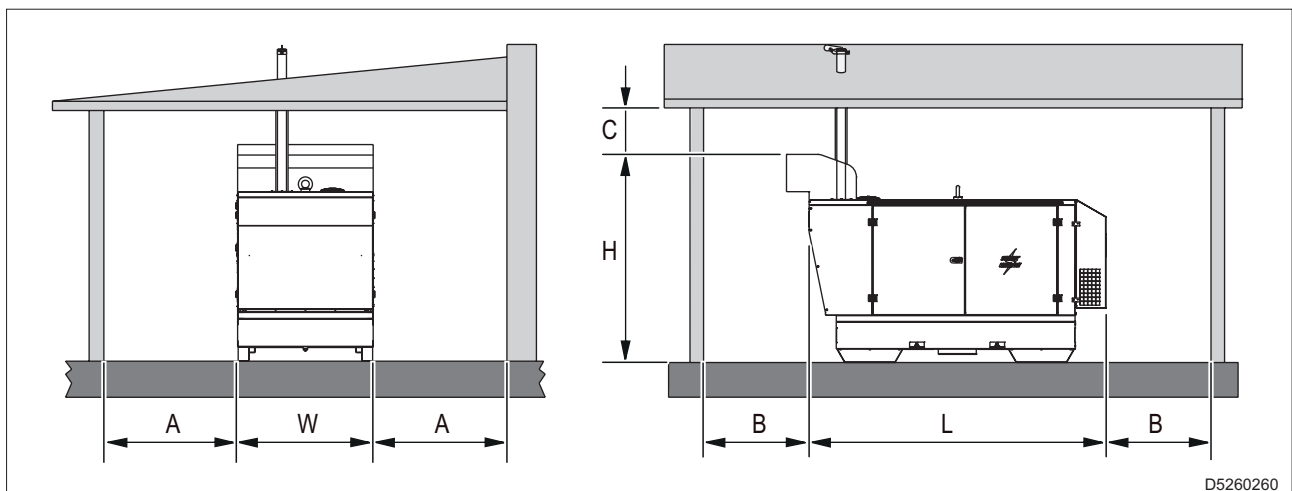

D5260260

W: Generating set width
 L: Generating set length
 H: Generating set height

A: >1000 mm
 B: >500 mm
 C= H+1500 mm (Min. 2500 mm)

5.3 Indoor installation

Important

- The room where the generating set will be installed must comply with the legislation in force at the place of installation.

Installation of the generating set indoor must be carried out in accordance with the instructions described.

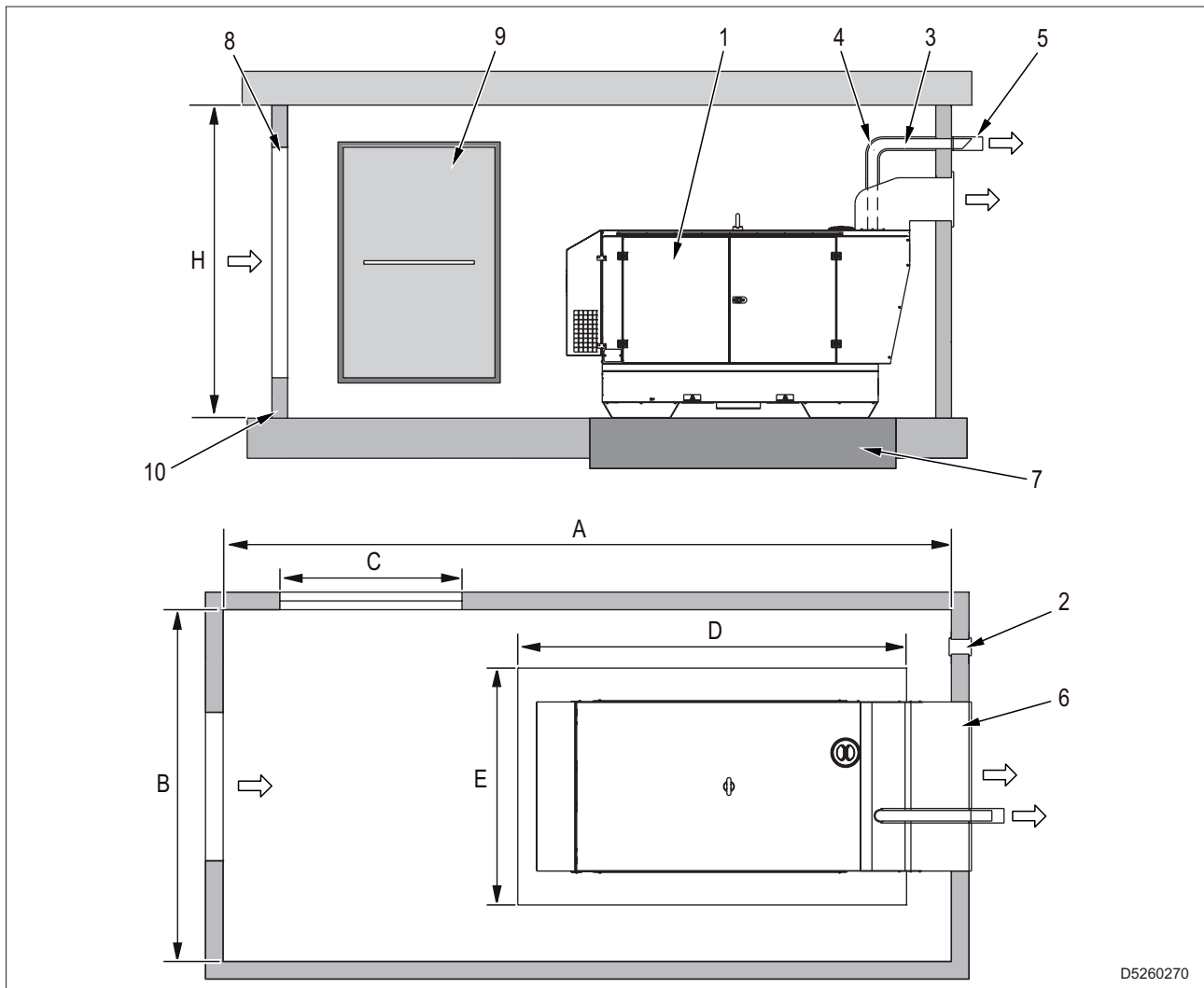

D5260270

- (1) Generating set
- (2) Auxiliary extractor
- (3) Exhaust pipes
- (4) Exhaust pipe protection and insulation
- (5) Rain cap and anti-intrusion hood
- (6) Air ejection duct
- (7) Platform with insulated foundation
- (8) Air inlet with anti-intrusion mesh
- (9) Entrance door
- (10) Containment step

Recommended minimum size

- (A) Generating set length + 1000 mm
- (B) Generating set width + 2000 mm
- (C) Generating set width + 200 mm
- (D) Generating set length + 400 mm
- (E) Generating set width + 400 mm
- (H) Generating set height + 1500 mm (Min. 2500 mm)

5.3.1 Supporting floor

For a correct support of the electronic unit and to avoid the transmission of vibrations, it is necessary to build a reinforced concrete platform (7) on the floor, isolated from the rest of the structure.

The generating set frame must be fixed to the platform (7) with dowels or anchor bolts.

The platform must have a length (D) and a width (E) greater than 400 mm (200 mm per side) with respect to the support base of the generating set (200 mm per side).

The weight of the platform must be 3 times the static weight of the generating set reported in the technical data.

The floor of the room must be level and adequate to support the weight of the generating set.

If the generating set is not equipped with a liquid containment tank, the door thresholds (9) or entrance to the room must have a plinth that can contain the liquids in case of leakage.

5.3.2 Opening and ventilation of the room

The room must have a sufficient ventilation system to dispose of the heat produced by the generating set during operation, without any possible stagnation or recycling of overheated air.

The inlet and outlet openings of the cooling and combustion air must be sized taking into account the minimum air flow rates and maximum back pressures reported in the engine manual.

The air inlet opening (8) must be positioned near the floor towards the rear of the generating set.

If the air inlet (8) and outlet (6) openings are not aligned with the generating set, ducts must be installed to convey the air and ensure ventilation of the room.

5.4 Grounding

Important

- Comply with local and/or current regulations on installation and electrical safety.

The grounding terminal (1) is in the position shown in figure.

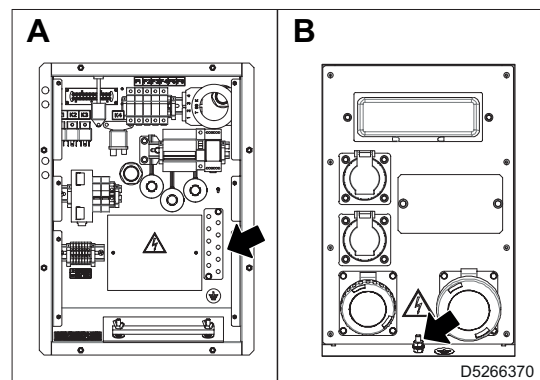

5.4.1 Grounding with residual current circuit breaker or earth leakage relay

Connection to a grounding system is mandatory for all models equipped with a residual current circuit breaker or earth leakage relay.

In these groups, the star centre of the generating set is generally connected to the machine ground.

By adopting the TN or TT distribution system, the differential relay guarantees protection against indirect contacts.

If powering complex systems that require or adopt additional electrical protection devices, coordination between the protections must be verified.

Use the grounding terminal (1) for connection.

5.4.2 Grounding with isolation monitor

In machines equipped with an insulation monitor, connection of the grounding terminal (1) to a grounding system is not required.

Located on the front of the machine, the isolation monitor continuously monitors the ground insulation of the active parts.

If the isolation resistance drops below the set fault value, the isolation monitor interrupts the power supply to the connected equipment.

It is important that the power cables of the equipment are equipped with the protective conductor (yellow-green cable) so as to ensure the equipotential connection between all the masses of the equipment and the mass of the machine.

This provision is not valid for double insulated or reinforced insulated equipment.

Note

You can connect the grounding terminal (1) to your own grounding system.

In this case, an IT-type system is created, that is, with the active parts isolated from the ground and the ground plane earthed.

In this case, the isolation monitor controls the isolation resistance of the active parts both towards ground and towards earth (for example, ground insulation of the power cables).

5.5 Electrical connections

Important

- Connection to the systems must be carried out by a qualified electrician, who must perform the connection according to the regulations in force at the place of installation.

The electrical connection to the user system is one of the most important operations to be carried out before use.

The safety and efficiency of the generating set and the user system itself depend on the correct connection. Before powering the user system, perform the following checks.

- 1 - The connection cables between the generating set and the user system must comply with the rated voltages of the system.
- 2 - The type of cable, section and length must be sized according to the environmental conditions of installation and local regulations.
- 3 - The earth connection must be efficient to allow correct operation of the differential protection device.
- 4 - The cyclical direction of the phases must correspond to the needs of the user system. Do not connect the phases to the neutral.

6. Operation



WARNING

- Before starting the machine, carefully read section “2. Safety”.
- It is forbidden to connect the set to the public grid and/or other source of electricity.
- **Continuous operation at low load**
In general, all machinery (in particular those equipped with motors with after-treatment devices) must operate with a load (i.e. absorbed power) equal to or greater than 20% of the nominal electrical power reported on the ID plate (value expressed in kW). This ensures a consistent efficiency and performance throughout their lives.
With loads below 20%, the machine should never be operated for more than 5 hours. Subsequently, the machine must be operated with a load greater than 20% for at least 30 consecutive minutes.

6.1 Operating conditions

6.1.1 Power

The electrical power of the generating set, expressed in kVA, is the available output power at the reference environmental conditions and at the rated values of: voltage, frequency, power factor ($\cos \phi$).

There are different types of power established by ISO 8528-1 and 3046/1:

- PRIME POWER (PRP)
- STAND-BY POWER
- COP

See “3. Technical data”.



Important

- When using the generating set, do not exceed the declared powers, paying particular attention when powering multiple loads at the same time.

6.1.2 Voltage

Alternators with Electronic Adjustment (AVR)

In these types of generating sets, the voltage accuracy is maintained within $\pm 1.5\%$ with speed variation between -10% and $+30\%$ and with balanced loads.

The voltage remains constant both without load and with connected loads that have a $\cos \phi$ between $0.8 \div 1$. The insertion and release of the load causes a change of transient voltage lower than 15% , with return to the rated value within $0.2-0.3$ seconds.

6.1.3 Frequency

Frequency is a parameter directly dependent on engine revolutions.

With a 4-pole alternator, you have a frequency of $50/60$ Hz with a rotational speed of $1500/1800$ rpm.

The generating set engine is equipped with a mechanical speed regulator.

The mechanical speed regulator has an idle to full load speed droop of less than 5% , while under static conditions, the accuracy is maintained within $\pm 1\%$.

- For 50Hz generators, the no-load frequency is $52-52.5$ Hz
- For 60Hz generators, the no-load frequency is $62.5-63$ Hz.

- The nominal frequency of 50Hz or 60Hz is reached at the maximum output power (kW) of the generating set

Power factor - $\cos \phi$

The power factor is a data that depends on the electrical characteristics of the load.

It indicates the ratio between the Active Power (kW) and the Apparent Power (kVA).

The apparent power is the total power required for the load, given by the sum of the active power delivered by the engine (after the alternator has transformed the mechanical power into electrical power) and the Reactive Power (kVAR) delivered by the alternator.

The rated value of the power factor is $\cos \phi = 0.8$.

For different values between 0.8 and 1, it is important during use not to exceed the declared active power (kW) so as not to overload the engine of the generating set; the apparent power (kVA) will decrease proportionally to the increase in $\cos \phi$.

For $\cos \phi$ values lower than 0.8, the alternator must be downgraded, because, at the same apparent power, the alternator should provide a greater reactive power.

For the reduction coefficients, contact the Technical Support Service.

Asynchronous motor start

Starting an asynchronous motor by a generating set can be critical, due to the high starting currents that the asynchronous motor requires (I_{avv.} = up to 8 times rated current I_n).

The starting current must not exceed the overload current allowed by the alternator for short periods, generally 250-300% for 10-15 seconds.

To avoid oversizing the group, we recommend adopting some precautions:

- When starting multiple motors, divide them into groups and arrange for them to start at intervals of 30-60 seconds.
- If the machine coupled to the motor allows it, set it for a reduced-voltage start, star/triangle start or with autotransformer, or use a soft-start system.

In all cases, when the user circuit provides for the start of an asynchronous motor, it is necessary to check that there are no utilities inserted in the system that, due to the transient voltage drop, may cause more or less serious disruptions (opening of contactors, temporary power failure to command and control systems, etc.).

Single-phase loads

The supply of single-phase utilities through three-phase generators requires some operational limitations.

- In single-phase operation, the declared voltage accuracy can no longer be maintained by the AVR electronic regulator, as the system becomes highly unbalanced.
The voltage variation is limited by the particular three-phase sensing AVR regulator, which tends to balance the three phase voltages.
When connecting multiple single-phase utilities, it is mandatory to distribute the utilities over the three phases, in order to balance the system as much as possible.
- The maximum withdrawable power between Neutral and Phase (star connection) is generally 33% of the rated three-phase power, or 40% if only one utility is connected on a single phase.

6.2 Checks before start-up

1 - Check that the battery disconnect switch is turned ON.

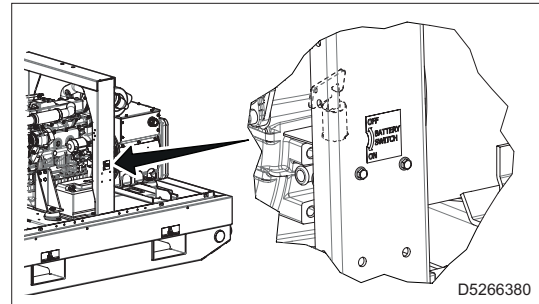

- 2 - Check the oil, fuel and coolant levels.
- 3 - Check that the engine compartment, radiator and battery access doors are locked.
- 4 - Check that there are no oil, fuel and coolant leaks.
- 5 - Check that there is no flammable or dirty material around the exhaust pipe.
- 6 - Check that there are no unauthorized persons in the area adjacent to the generating set.
- 7 - Check that the main machine switch is in the OFF position (insertion lever downwards). For the details, see "4.2.1 Main machine switch".
- 8 - Before each work session, if the distribution system adopted requires it, check the effectiveness of the earth connection of the generating set (e.g., TT and TN systems).
- 9 - Check that the electrical characteristics of the devices to be supplied, voltage, power, frequency, are compatible with those of the generating set.
Too high or too low values of voltage and frequency can irreparably damage the electrical equipment.
In some cases, when powering three-phase loads, it is necessary to ensure that the cyclical direction of the phases corresponds to the needs of the system.
- 10 - Connect the utilities to be powered using suitable cables and plugs, in excellent condition.

6.3 Starting the generating set

WARNING

- Do not alter the primary adjustment conditions and do not tamper with sealed parts.

The engine is started and stopped by acting directly on the IL-4 AMF 9 control unit. Consult the control unit manual for complete knowledge of its characteristics and performance.

- 1 - Check that the main machine switch (1) is set to OFF (insertion lever downwards), in order to ensure that the engine starts without loads engaged.
- 2 - Connect the cables or the mobile plug of the load to the generating set.

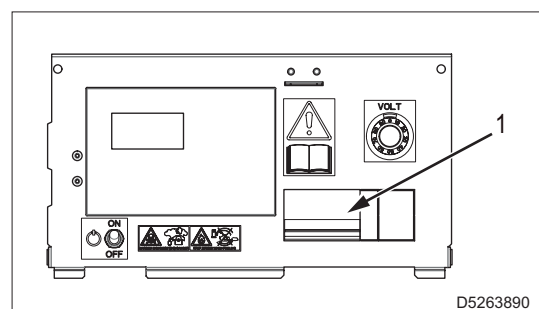

3 - Turn the control panel power switch (2) ON.

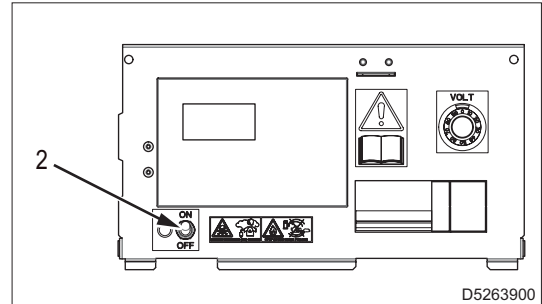

4 - Press the start button (3) to launch the generating set start sequence.

Note

The start button only works in MAN mode.

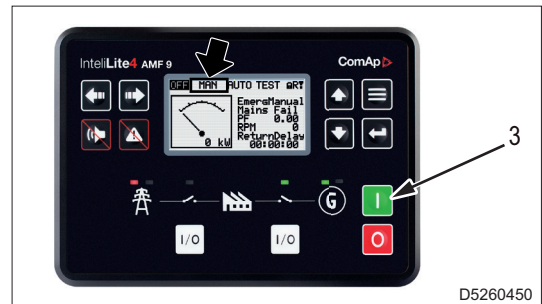

5 - Before drawing a load, let the engine run for the time shown in the following table.

Ambient temperature	Time required
≤15°C	5 minutes
-14°C – -10°C	2 minutes
-9°C – -5°C	1 minute
≤ -4°C	20 seconds

Note

For starting and use at temperatures below -10°C, refer to the engine instruction manual or contact the Technical Support Service.

6 - Set the main machine switch (1) to ON (insertion lever upwards).

7 - Turn all residual current circuit breakers with overcurrent protection (RCBO) and the residual current circuit breakers (6) that protect the utilities connected to the output sockets to ON.

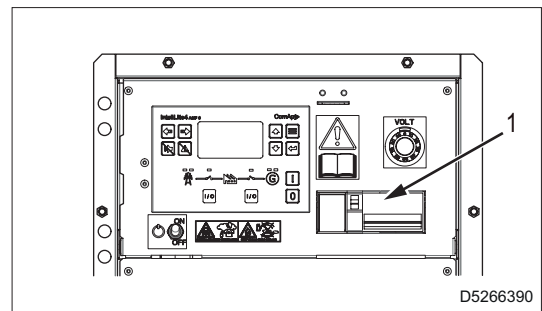

Note

- It is advisable not to set the switches of unused output sockets to ON.
- Before powering the utilities, check that the values of the voltages and the frequency correspond to the rated values on the control unit.

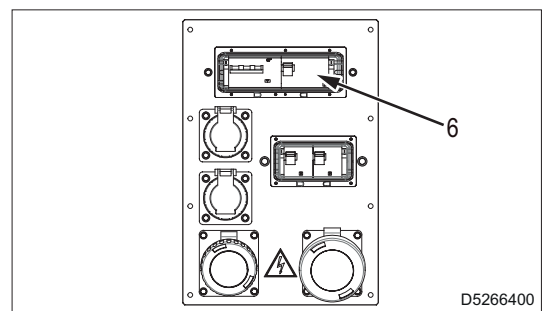

6.4 Stopping the generating set

- 1 - Turn off the loads connected to the generating set.
- 2 - Set the main machine switch (1) to OFF (insertion lever downwards).

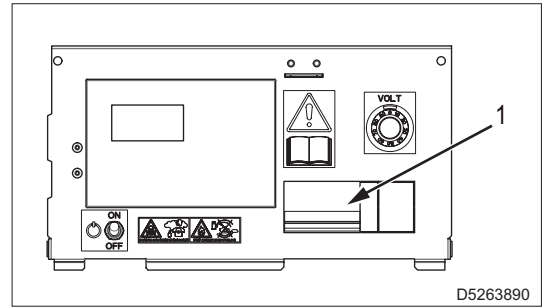

- 3 - Press the stop button (7) to launch the generating set stop sequence.
The engine stops at the end of the cooling cycle.
For immediate stop, press the stop button (7) again.

Note

The stop button works in MAN mode.

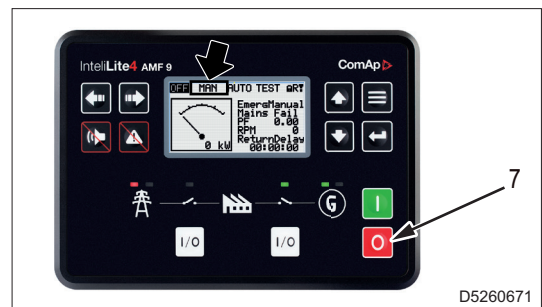

- 4 - Turn the control panel power switch (2) OFF.
- 5 - Turn the battery disconnect switch to OFF.

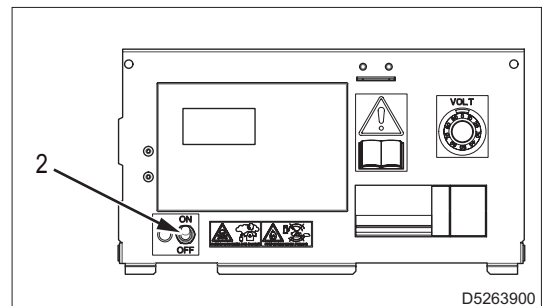

6.5 Emergency stop

For an emergency stop, press the emergency button (8).
To reset the button, turn it clockwise.

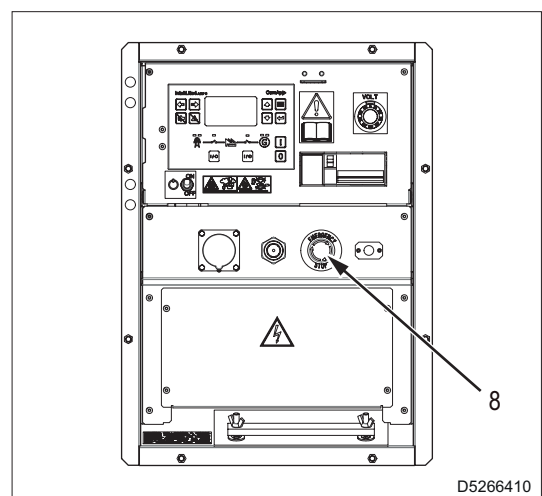

7. Maintenance



WARNING

- Before proceeding with maintenance, carefully read section “2. Safety”.

7.1 Refuelling

Use fuel, coolant and lubricants according to the ambient temperature.

7.1.1 Fuel

The fuel must comply with EN590 and ASTM D975.

The cetane number of the fuel should be at least 45.

In order to ensure an efficient and long service life of the engine, the fuel must be sulphur-free diesel fuel:

- EN 590
- DIN 5168
- ASTM D975 Grade 2-D S15,
- ASTM D975 Grade 1-D S15

Using fuel with a high sulphur content could reduce the life of the engine, or cause damage to the machine or decrease its performance.

Do not use dirty diesel or mixtures of diesel and water, as this would cause serious engine failure.

Clean fuel prevents clogging of fuel injectors.

Do not store the diesel in zinc coated containers.

Use the fuel in the storage tank or the fuel tank of the machine within 6 months.

Fuel deterioration reduces the quality of combustion and can cause engine power loss, increased fuel consumption, and damage to engine components.

To use other types of fuel, such as low-temperature fuels, biodiesel, synthetic, non-road fuel, etc., consult the engine manual.

Refuelling



WARNING

- Before refuelling, read “2.8 Precautions during fuel and engine oil filling” carefully.

Do not fill the tank completely. Leave a gap of about 10 mm, between the fuel level and the top wall of the tank, to allow expansion.

Keep the engine off during refuelling.

7.1.2 Engine oil

- To ensure adequate protection of the engine and keep it efficient for a long time, use only the recommended oil. Using different oils can reduce the life of the engine.
- The viscosity must be appropriate to the ambient temperature.
- The oil to be used must comply with the following specifications:

API	CJ-4 Low S.A.P.S
ACEA	E6 Low S.A.P.S.

Low S.A.P.S. (low sulphated ash, phosphorus, sulphur oil) keeps the catalyst in good working condition.

SAE oil classification

In the SAE classification, oils are identified according to the viscosity.

The code is composed of two numbers, which indicate, and must correspond to the ambient temperature at which the engine operates.

The first number refers to the cold viscosity, for winter use (W), while the second number refers to the viscosity at high temperatures.

SAE 10W-30	-25°C to +40°C
SAE 10W-40	-25°C to +50°C
SAE 5W-30	-30°C to +40°C
SAE 0W-40	-40°C to +50°C

Refuelling and checks



WARNING

- Before refuelling, read “2.8 Precautions during fuel and engine oil filling” carefully.
- Do not introduce more oil than indicated in the engine manual. Combustion of excess oil may result in increased engine revolutions.

1 - Remove the engine fill cap (1).

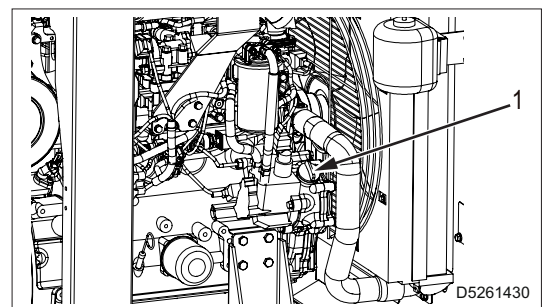

2 - Refuel and refit the cap.

3 - Check the level with the rod (2).

The level must be between the minimum and maximum notches.

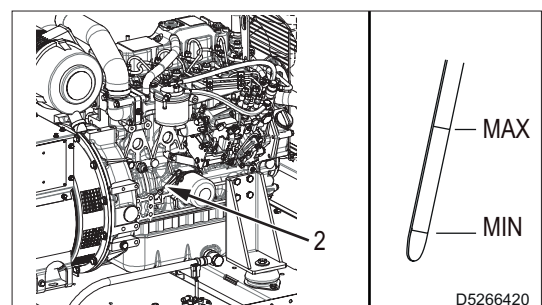

7.1.3 Coolant

The engine cooling system is fuelled with OAT: ENI ANTIFREEZE SPEZIAL coolant, mixed at 50% with demineralised water.

It is recommended to continue using the same coolant.

If the type of coolant is changed for refuelling, the system must be thoroughly washed.

By mixing with each other, the residues of additives of different types contained in the different liquids would create gelatinous substances that could obstruct the system.

Use a mixture of 50% demineralised water and 50% low silicate ethylene glycol coolant.

Use a coolant free from silicates, phosphates, borates, nitrites and amines.

The following ethylene glycol based engine coolants may be used:

- low silicate OAT (Organic Acid Technology): ASTM D-3306 D-6210
- low silicate HOAT (Hybrid Organic Acid Technology): ASTM D-3306 D-6210

Important

- Do not mix OAT and HOAT coolants.
- Never use automotive coolants. These coolants do not contain the correct additives to protect heavy-duty diesel engines.

Oat coolants are maintenance-free for up to 6 years or 6000 operating hours, provided that the cooling system is topped up using the same type of coolant.

Do not mix different types of coolant.

Test the coolant condition annually with coolant test strips.

HOATs are not all maintenance-free and it is recommended to add SCA (Supplemental Coolant Additives) at the first maintenance interval.

Refuelling

WARNING

- Before refuelling, read “2.9 Maintenance precautions” carefully.

Check the coolant level when the engine is cold.

1 - Open the radiator cap access door (1).

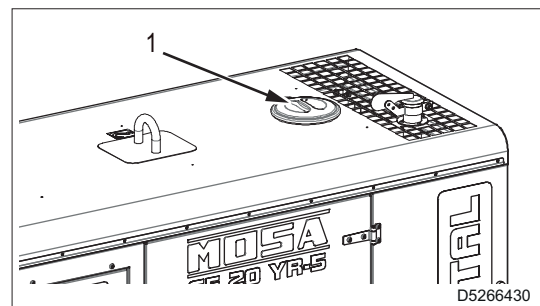

- 2 - Remove the cap (2) and pour the coolant into the radiator.
- 3 - Top up the liquid until it covers the pipes inside the radiator by about 5 mm.

Note

- Do not overfill the radiator; allow room for coolant expansion.
- 4 - Refit the cap (2) and tighten securely.
 - 5 - After the top-up operations, run the engine for a short period, check the coolant level again and refill if necessary.

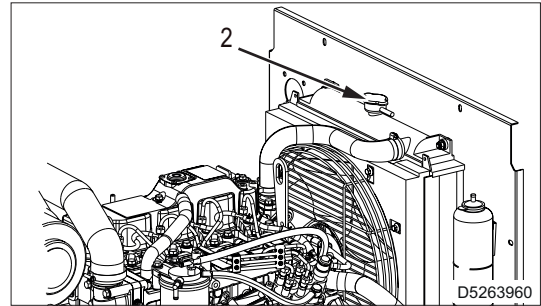

7.1.4 Checking and cleaning the engine air filter

- 1 - Release the hooks (1).
- 2 - Pull out the filter element (2).
- 3 - Using a damp cloth, clean the inside of the cover (3) and the outer element (4).
- 4 - Blow air through elements (2) using compressed air at 0.29 - 0.49 MPa (3.0 - 5.0 kgf/cm²).

Important

- Use low-pressure compressed air to prevent filter damages.
- 5 - Insert the filter elements (2) into the outer element (4)
 - 6 - Fit the cover (3) in the direction indicated on the cover arrow, and couple it using the hooks (1).

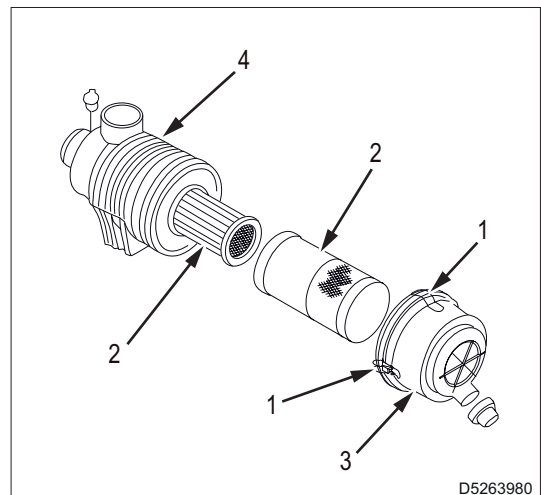
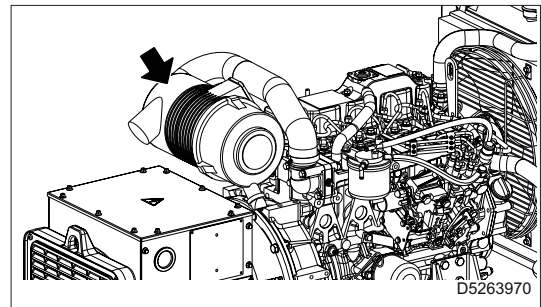

7.2 Routine maintenance



WARNING

- Pay the utmost attention to the generating sets equipped with an automatic or remote intervention system.
Make sure that the generating set does not start during routine maintenance or repair operations by carrying out the following operations:
 - **Disconnect power to the generating set control board.**
 - **Press the emergency button.**

Note

For engine maintenance, refer to the engine maintenance manual.

Every day

- Check coolant level
- Check engine oil level
- Check fuel level
- Check for sediment and water in fuel filter/separator

After the first 50 hours

- Check cooling fan belt
- Replace the engine oil filter and engine oil

Every 50 hours

- Check and clean radiator fins
- Check battery charge
- Clean sediment and water in fuel filter/separator

Every 250 hours

- Check cooling fan belt
- Replace the engine oil filter and engine oil
- Check and adjust regulator lever, check engine speed
- Drain fuel from tank
- Clean air filter

Every 500 hours

- Clean fuel filter/separator
- Replace the fuel filter
- Replace the air filter element

Every 1000 hours

- Replace coolant (or every 1 years, even if the 1000 hours have not been reached)
- Adjust intake/discharge valve clearance

Every 1500 hours

- Check fuel injectors
- Check engine base ventilation system

Every 2000 hours

- Check fuel line, coolant, oil and ventilation pipes (or every 2 years, even if the 2000 hours have not been reached)

7.3 Precautions for generating sets with automatic or remote start-up

- Pay the utmost attention to the generating sets with automatic or remote start-up system, including:
 - Generators in emergency service to the mains.
 - Generators with programmable automatic test function.
 - Generators with remote control via PC, via telephone modem or GSM modem and other communication systems.
 - Generators with radio control.
 - Generators with remote contact start-up: timer, float, etc.
 - Generators with TCM remote control.
- To mitigate potential safety hazards arising from automatic or remote start-up, house the generating set in an enclosed area, restricting access to authorised personnel only.
- If installation of the generating set indoors is not feasible, ensure the surrounding area is isolated and clearly marked to prohibit access by unauthorised personnel.
- Exercise caution when dealing with machinery in emergency service to the mains.
If, due to maintenance, the generating set is disconnected, it starts automatically, generating a hazard for the maintenance technician.
- Make sure that the generating set does not start during routine maintenance or repair operations by placing it in “Block” mode.
- Always disconnect devices powered by the mains such as preheating systems or the battery charger. They remain energised if they are not disconnected.
- The generating set may be connected to a system where a power failure could generate critical circumstances.
At the end of maintenance, restore the automatic operation of the generating set.



7.4 Maintenance of generating sets with automatic intervention system

For generating sets preset for automatic intervention, in addition to carrying out all the periodic maintenance operations required for normal use, some operations necessary for the particular type of use must be carried out.

The generating set must be continuously set up for operation even after long periods of inactivity.

Every week

- Carry out a TEST cycle or AUTOMATIC NO-LOAD TEST cycle to keep the generating set constantly operating
- Check engine oil, fuel, battery electrolyte levels. If necessary, top up with oil.

Every month and/or after a load operation

- Carry out a TEST cycle or AUTOMATIC LOAD TEST cycle to keep the generating set constantly operating
- Check engine oil, fuel, battery electrolyte levels. If necessary, top up with oil.
- Check electric connections and clean control panel.

Every year

- Check electric connections and clean control panel.
- Replace the engine oil.

7.5 Storage

- Carefully clean the fairings and all other machine parts.
- Run the machine with load every 10 days for 15-30 minutes.
Doing so ensures proper lubrication of the engine, keeps the battery charged and prevents any blockage of the injection system.
- If the machine is not used for more than 30 days, make sure that the machine is protected from heat sources and from weather phenomena that can cause rust, corrosion of the components and damage to the machine.
- Protect the machine with a case and store it in a dry place.
- Use qualified personnel to carry out the operations necessary for storage.
- For the correct engine storage, follow the instructions in the manual or contact the engine manufacturer's Technical Support.

7.6 Disposal



WARNING

- **Before refuelling, read “2.9 Maintenance precautions” and “2.10 Precautions for disposal of waste material”.**

In the event of disposal of the machine or parts of it (oils, hoses, plastic materials, etc.), comply with the regulations in force in the country in which this operation is carried out.

- For further information, visit <https://bcsgroup.it/it-it/sostenibilita/#etichettatura-ambientale> or scan the QR code.



8. Overall dimensions for installation

(1/2)

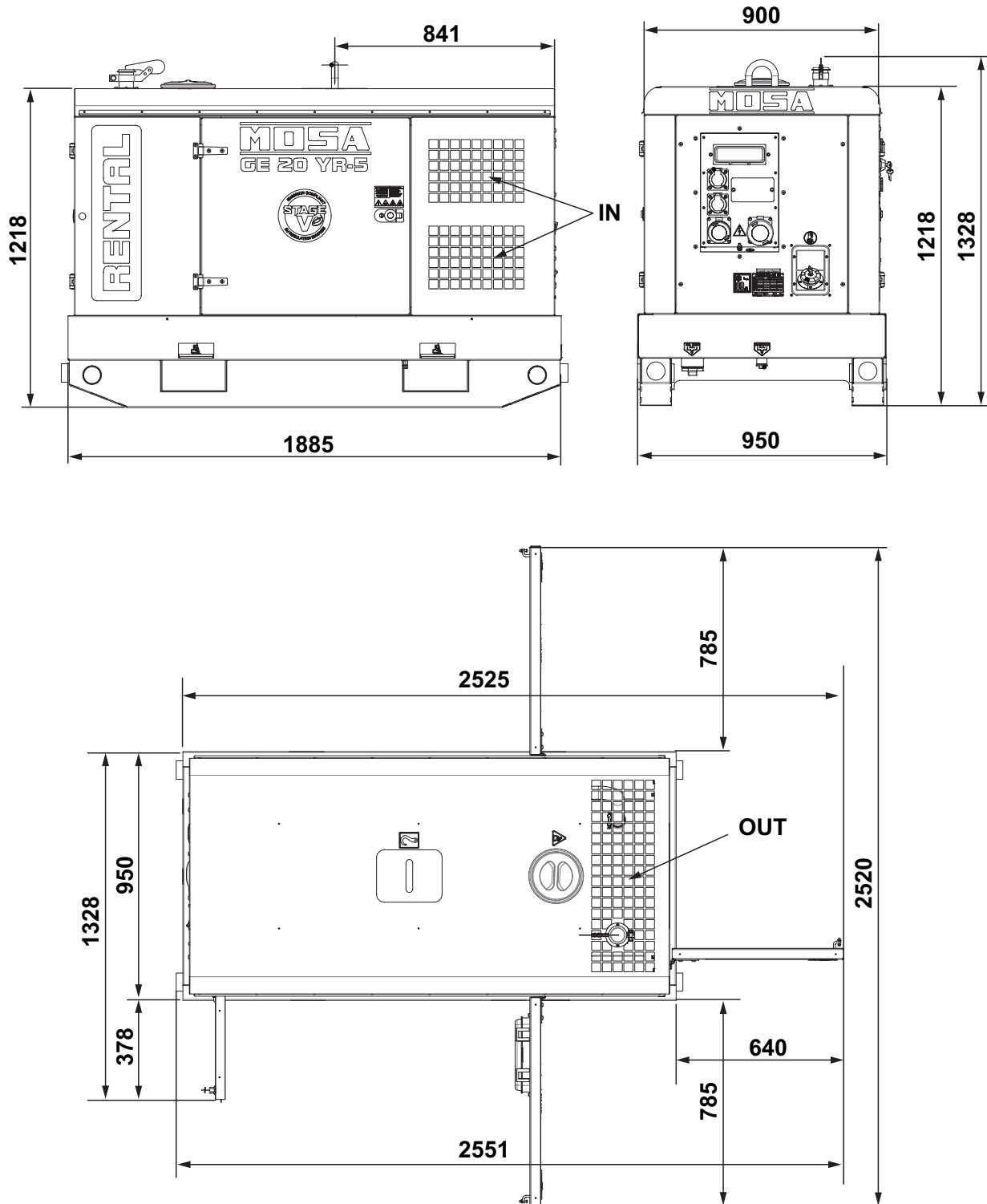

D5266470

IN - Air inlet grid
 OUT - Air outlet grid

(2/2)

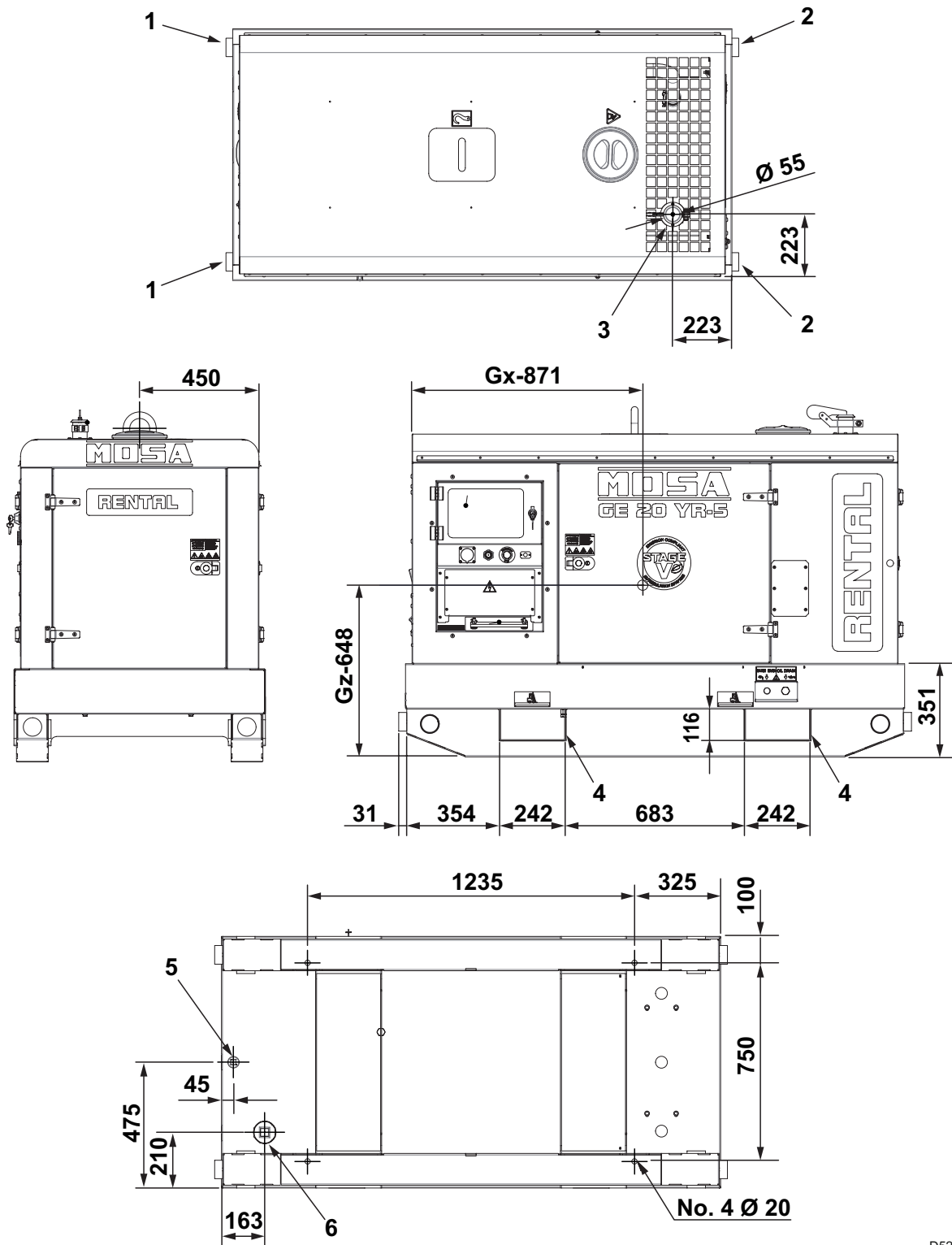

D5266480

- 1 - Front bumper
- 2 - Rear bumper
- 3 - Exhaust pipe
- 4 - Anti-tip side pockets for handling with forklift trucks
- 5 - Fluid drain plug in the base
- 6 - Fuel drain plug in the tank



MOSA div. della BCS S.p.A.

Viale Europa, 59 20047 Cusago (Milano) Italy
Tel.+39 - 0290352.1 Fax +39 - 0290390466 www.mosa.it